

# dji AGRAS T25 P

## User Manual

v1.0 2026.01

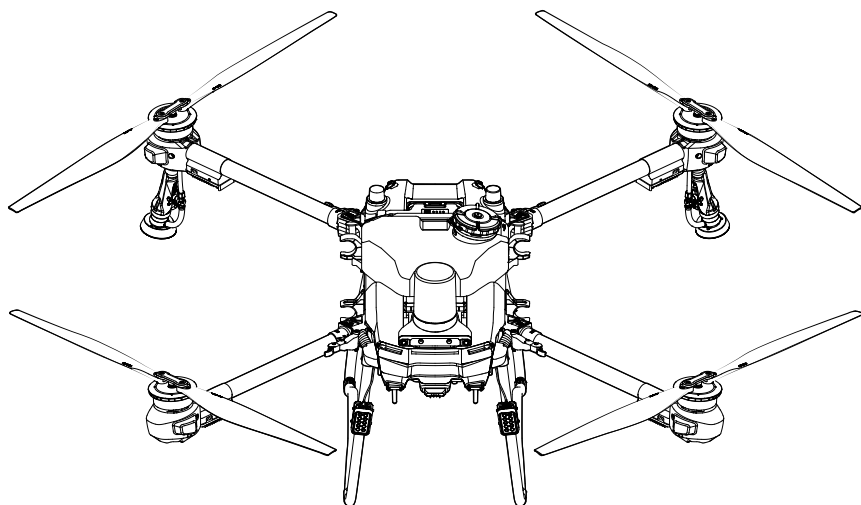



This document is copyrighted by DJI with all rights reserved. Unless otherwise authorized by DJI, you are not eligible to use or allow others to use the document or any part of the document by reproducing, transferring or selling the document. Only refer to this document and the content thereof as instructions to operate DJI products. The document should not be used for other purposes.

In the event of divergence among different versions, the English version shall prevail.

#### **Searching for Keywords**

Search for keywords such as “battery” and “install” to find a topic. If you are using Adobe Acrobat Reader to read this document, press Ctrl+F on Windows or Command+F on Mac to begin a search.

#### **Navigating to a Topic**

View a complete list of topics in the table of contents. Click on a topic to navigate to that section.

#### **Printing this Document**

This document supports high resolution printing.

## Information

 The aircraft may not come with a flight battery in certain regions. Only purchase official DJI™ flight batteries. Read the corresponding Intelligent Flight Battery user guide and take necessary precautions when handling the batteries to ensure your own safety. DJI assumes no liability for damage or injury incurred directly or indirectly from misusing batteries.

 The operating temperature of this product is 0° to 40° C (32° to 104° F). It does not meet the standard operating temperature for military grade application (-55° to 125° C (-67° to 257° F)), which is required to endure greater environmental variability. Operate the product appropriately and only for applications that it meets the operating temperature range requirements of that grade.

## Legend

 Important

 Hints and Tips

 Reference

## Read Before Use

DJI™ provides you with tutorial videos and the following documents:

1. *Safety Guidelines*
2. *Quick Start Guide*
3. *User Manual*

It is recommended to watch all the tutorial videos and read the *Safety Guidelines* before using for the first time. Make sure to review the *Quick Start Guide* before using for the first time and refer to this *User Manual* for more information.

## Video Tutorials

Go to the address below or scan the QR code to watch the tutorial videos, which demonstrate how to use the product safely:



<https://ag.dji.com/t25p/video>

## Download DJI Assistant 2 For MG

Download DJI ASSISTANT™ 2 For MG from:

<https://www.dji.com/downloads/softwares/assistant-dji-2-for-mg>

## Downloading DJI SmartFarm

Scan the QR code to download DJI SmartFarm, which provides end-to-end service support for the operation.



# Contents

<b>Information</b>	<b>2</b>
Legend	2
Read Before Use	3
Video Tutorials	3
Download DJI Assistant 2 For MG	3
Downloading DJI SmartFarm	3
<b>1 General Information and System Description</b>	<b>8</b>
1.1 Using for the First Time	8
Charging	8
Preparing the Remote Controller	9
Adjusting the Antennas	9
Mounting the RTK Dongle	9
Preparing the Aircraft	10
Activation	10
1.2 Aircraft	11
Overview	11
T25P	11
Propulsion System	11
Safety System	12
Detection Range	12
Obstacle Avoidance Function	12
Using Terrain Follow and Bypassing Functions	13
Radar Usage Notice	13
Vision System Usage Notice	14
Aircraft LEDs	15
Aircraft Indicators	15
Spotlight	15
Flight Modes	16
Aircraft RTK	16
Enabling/Disabling RTK	16
Custom Network RTK	16
1.3 Control Station	17
Remote Controller	17
Overview	17
Charging the Batteries	18
Using the Remote Controller	19
Remote Controller LEDs	21
Remote Controller Alert	22

	Optimal Transmission Zone	22
	Linking the Remote Controller	22
	HDMI Settings	23
	Installing the Strap	23
	DJI Agras App	23
	Home Screen	24
	Operation View	25
1.4	Command and Control Link (C2 Link)	26
<b>2</b>	<b>Performance and Limitations</b>	<b>27</b>
2.1	Performance	27
	T25P	27
2.2	Prohibited Maneuvers	28
2.3	Flight Environment Requirements	28
<b>3</b>	<b>Normal Procedures</b>	<b>30</b>
3.1	Airspace Environment	30
	GEO (Geospatial Environment Online) System	30
	GEO Zones	30
	Flight Restrictions	30
	Flight Altitude and Distance Limits	32
3.2	Interference with Flight Controller and Communications	33
3.3	Calibrating the Compass	33
3.4	Basic Flight	34
	Pre-Flight Checklist	34
	Starting and Stopping the Motors	35
	Starting the Motors	35
	Stopping the Motors	35
	Stopping the Motors Mid-Flight	35
	Take Off	36
	Landing	36
3.5	Cruise/Maneuvering Flight	37
	Controlling the Aircraft	37
	Operation Mode	38
	Return to Home	38
	Notices	39
	Smart RTH	39
	Low Battery RTH	39
	Failsafe RTH	40
	Obstacle Avoidance During RTH	40
	Landing Protection Function	41
3.6	Flight Data	41

3.7	Storage, Transportation and Maintenance	41
	Storage and Transportation	41
	Maintenance	42
<b>4</b>	<b>Emergency Procedures</b>	<b>43</b>
4.1	Obstacle Avoidance	43
4.2	Critical Low Battery/Critical Overheated Warning	43
4.3	Loss of Navigation Systems	43
4.4	Loss of C2 Link	43
4.5	Single Propulsion Failure	44
4.6	Aircraft Out of Control	44
4.7	Aircraft Crash	44
4.8	Flyaway	45
4.9	Fire	45
<b>5</b>	<b>Operation</b>	<b>46</b>
5.1	Calibrating the Flow Meter	46
5.2	Mapping Operation	46
	Operation Procedure	46
	Reconstruction Result Application	47
5.3	Spraying Operation	47
	Downloading Prescription Maps	47
	Downloading/Importing Operations	48
	Planning an Operation	48
	Planning Route Operation	48
	Planning Fruit Tree Operation	48
	Notices	49
	Performing an Operation	49
	Performing Route/Fruit Tree Operation	49
	Performing A-B Route Operation	51
	Multitask	52
	Manual Operation	53
5.4	Operation Resumption	53
	Recording a Breakpoint	53
	Resumption Procedure	54
	Smart Resume	54
	Resuming Operation	54
5.5	Empty Tank Warning	55
<b>6</b>	<b>Intelligent Flight Battery</b>	<b>57</b>
6.1	Overview	57
6.2	Warnings	57

---

6.3	LED Patterns	59
	Checking the Battery Level	59
	Battery Level LEDs	59
	Battery Error LED Patterns	60
6.4	Storage and Transportation	61
6.5	Maintenance	61
6.6	Disposal	61
<b>7</b>	<b>Appendix</b>	<b>63</b>
7.1	Specifications	63
7.2	Firmware Update	63
	Using DJI Agras	63
	Using DJI Assistant 2	63
	Notices	64
7.3	Using Enhanced Transmission	64
	Inserting the nano-SIM Card	65
	Installing the DJI Cellular Dongle	65
	Using Enhanced Transmission	66
	Security Strategy	66
	Remote Controller Usage Notes	67
	4G Network Requirements	67
7.4	Recommended Maintenance Cycle	67
7.5	FAR Remote ID Compliance Information	74

# 1 General Information and System Description

## 1.1 Using for the First Time

### Charging

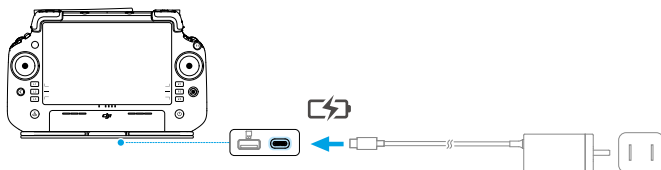
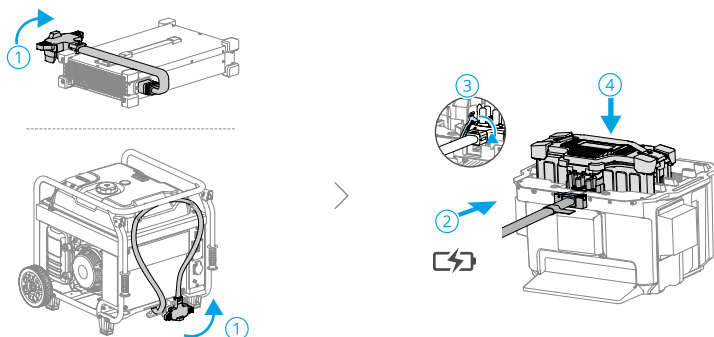

💡 Charge to activate the internal battery of the remote controller before using for the first time. Otherwise, it cannot be powered on. The battery level LEDs start to flash to indicate that the internal battery is activated.

## Preparing the Remote Controller

### Adjusting the Antennas

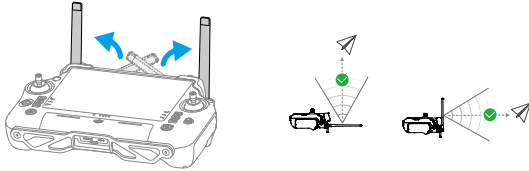

### Mounting the RTK Dongle

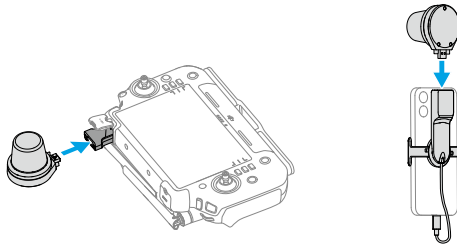

## Preparing the Aircraft

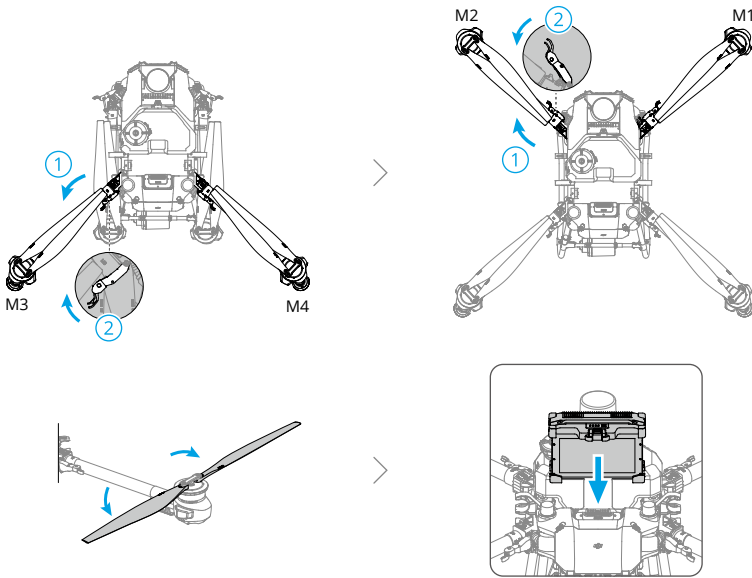

- 
-  • Make sure that the battery is firmly attached to the aircraft. Only insert or remove the battery when the aircraft is powered off.
- To remove the battery, press and hold the clamp and lift the battery up.
  - When folding the arms, make sure to fold them in the reverse order of unfolding, and ensure that the arms are secured to the storage clamps on both side of the aircraft. Otherwise, the arms may be damaged.
- 

## Activation

The aircraft and remote controller require activation before using for the first time. Press, and then press again and hold the power button to power on the devices. Follow the on-screen prompts to activate. Ensure that the remote controller can access the internet during activation.

## 1.2 Aircraft

### Overview

#### T25P

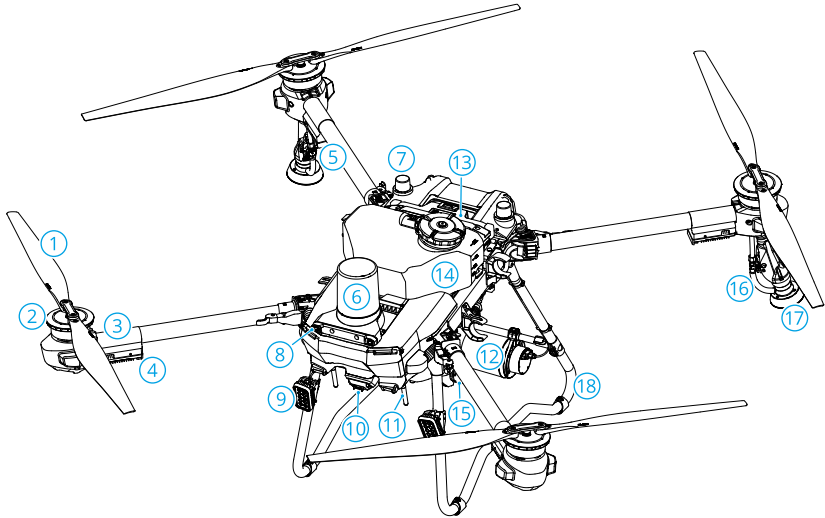

- |                                      |   |
|--------------------------------------|---|
| 1. Propellers                        | 11. External OCUSYNC™ Image Transmission Antennas |
| 2. Motors                            | 12. Rear Radar                                    |
| 3. Electronic Speed Controller (ESC) | 13. Intelligent Flight Battery                    |
| 4. Front Indicators                  | 14. Spray Tank                                    |
| 5. Rear Indicators                   | 15. Delivery Pumps                                |
| 6. Forward Radar                     | 16. Spray Lance                                   |
| 7. Onboard D-RTK™ Antennas           | 17. Sprinklers                                    |
| 8. Vision System                     | 18. Landing Gear                                  |
| 9. Spotlight                         |   |
| 10. FPV Camera                       |   |

### Propulsion System

The propulsion system consists of motors, ESCs, and folding propellers, to provide stable and powerful thrust.

- ⚠ • Only use official DJI propellers. DO NOT mix propeller types.
  - Propellers are consumable components. Purchase additional propellers if necessary.
  - Make sure the motors are mounted securely and rotating smoothly. Land the aircraft immediately if a motor is stuck and unable to rotate freely.
  - Make sure the ESCs sound normal when powered on.
- 

## Safety System

### Detection Range



View the following website for more information.

<https://ag.dji.com/t25p/specs>

---

- ⚠ • Radar and vision systems have detection blind spots. Fly with caution.
  - The aircraft cannot sense obstacles that are not within the detection range. Fly with caution.
  - The effective detection range varies depending on the size and material of the obstacle. Obstacle sensing may be affected or unavailable in areas outside of the effective detection distance.
  - Fly with caution when operating near obstacles that are aligned with or below the aircraft's underside.
  - To ensure safety, it is recommended to mark objects such as wires and inclined wires as obstacles when planning the field.
- 



### Obstacle Avoidance Function

In Operation View, tap  >  to enter Sensing Settings, and enable **Multidirectional Obstacle Avoidance**. When enabled, the aircraft will activate obstacle avoidance mode upon detecting obstacles. User can control the aircraft to fly in a direction away from the obstacle according to the prompt in the app.

---

- ⚠ In some scenarios such as with power lines, small obstacles, or objects that are at the same level as the landing gear, obstacle sensing may be rendered ineffective. Fly with caution. Manually control the aircraft if necessary to prevent flight accidents.
-

## Using Terrain Follow and Bypassing Functions

In Operation View, tap  >  to enter Sensing Settings and select the scenario as **Flatland**、**Hill/Orchard** or **Water**, then enable **Altitude Stabilization** and **Obstacle Bypassing** accordingly. The aircraft will follow terrain automatically and adjust its altitude during flight based on the set height above crops, and bypass detected obstacles. Moving the control stick can pause auto bypassing. The aircraft will hover in place if it fails to avoid the obstacle automatically. User can manually bypass the obstacle by controlling the aircraft.

- 
-  • Select the scenario according to the actual environment. Otherwise, the aircraft may not be able to keep the set height above crops or fail to bypass obstacles.
  - Obstacle bypassing is unavailable in Manual mode. The aircraft will hover in place after encountering an obstacle instead of automatically bypassing them.
  - When flying at night, in dark areas, or when the vision cameras are dirty, the aircraft will use radar for terrain following. Fly with caution.
  - After the additional sprinklers are mounted, the performance of the vision system may be affected by spray droplets. Fly with caution.
  - In some scenarios such as with power lines or small obstacles, the aircraft may not be able to bypass the obstacle successfully. Users can manually bypass the obstacle by controlling the aircraft.
  - Altitude stabilization will be affected when the aircraft is flying over water. Fly with caution. Make sure the relative flight altitude is higher than 2 m to avoid any accidents with the aircraft.
- 

## Radar Usage Notice

- 
-  • DO NOT touch or let your hands or body come in contact with the metal parts of the radar module when powering on or immediately after flight as they may be hot.
  - Maintain full control of the aircraft at all times and do not rely completely on the radar module and the app. Keep the aircraft within VLOS at all times. Use your discretion to operate the aircraft manually to avoid obstacles.
  - In Manual operation mode, users have complete control of the aircraft. Pay attention to the flying speed and direction when operating. Be aware of the surrounding environment and avoid the blind spots of the radar module. Make sure to appropriately use the radar module according to the surrounding environment.
  - The obstacle avoidance functions are disabled in Attitude mode.

- Fly with caution when encountering the following objects with limited radar detection performance.
  - ♦ Inclined lines, utility poles with significant tilt (exceeding 10°), or power lines at an inclined angle against the flying direction of the aircraft.
  - ♦ Vertical pole-shaped objects when the downward radar is above the top of the object.
  - ♦ Objects with complex structures, such as power towers.
- The radar module enables the aircraft to maintain a fixed distance from vegetation only within its working range. Observe the distance of the aircraft from vegetation at all times.
- Operate with extra caution when the aircraft is flying above surfaces with tilt angles exceeding the following values.
  - ♦ 10° (≤ 1 m/s)
  - ♦ 6° (≤ 3 m/s)
  - ♦ 3° (≤ 5 m/s)
- Comply with local radio transmission laws and regulations.
- The radar module is a precision instrument. DO NOT squeeze, tap, or hit the radar module.
- Before use, make sure that the radar module is clean and the outer protective cover is not cracked, chipped, sunken, or misshapen.



- Keep the protective cover of the radar module clean. Clean the surface with a soft damp cloth and air dry before using again.
- 

## Vision System Usage Notice

---



- The performance of the vision system is affected by the light intensity and the patterns or texture of the surface being flown over. Operate the aircraft with great caution in the following situations:
  - ♦ Flying near monochrome surfaces (e.g., pure black, white, red, or green surfaces).
  - ♦ Flying over highly reflective surfaces.
  - ♦ Flying over water or transparent surfaces.
  - ♦ Flying in an area where the lighting changes frequently or drastically.
  - ♦ Flying near extremely dark (<5 lux) or bright (>10,000 lux) surfaces.
  - ♦ Flying over surfaces with repeating identical patterns or textures or with particularly sparse patterns or textures.

- Flying over ground without clear patterns or textures.
  - Keep the cameras of the vision system clean at all times.
- 
-  Before cleaning the dust and other debris on the surface of the visual system, make sure the aircraft is powered off and then wipe it with a clean, soft cloth.
- 



## Aircraft LEDs

### Aircraft Indicators

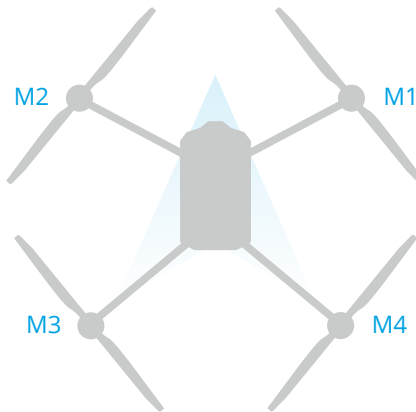
There are LEDs on the frame arms marked M1 to M4. The LEDs on frame arms M1 and M2 are front LEDs that blink slowly in red to indicate the front of the aircraft. The LEDs on frame arms M3 and M4 are rear LEDs that blink slowly in green to indicate the rear of the aircraft. All the LEDs are turned off when the aircraft is grounded. The front LEDs blink quickly in red and the rear LEDs blink quickly in green when the motors start spinning. Make sure to take off immediately.



## Spotlight

The aircraft is equipped with spotlights to enhance flight safety. Go to Operation View, tap  >  to enable/disable the spotlight.

---

 DO NOT look directly at the spotlight when it is in use to avoid eye damage.

---

## Flight Modes

**Normal (N/F) Mode:** Precise hovering and positioning are available. When the RTK module is enabled, it provides centimeter-level positioning.

**Attitude (S) Mode:** Precise hovering is unavailable and the aircraft can only maintain altitude. The flight speed in A-mode depends on the surroundings of the aircraft, such as wind speed.

### Attitude Mode Warning

In A-mode, the aircraft cannot position itself and is easily affected by its surroundings, which may result in horizontal shifting. Use the remote controller to position the aircraft.

Maneuvering the aircraft in Attitude mode can be difficult. Before switching the aircraft into Attitude mode, make sure you are comfortable flying in this mode. **DO NOT** fly the aircraft too far away as you might lose control and cause a potential hazard. Avoid flying in confined spaces or in areas where the GNSS signal is weak. Otherwise, the aircraft will enter A-mode, leading to potential flight risks. Land the aircraft in a safe place as soon as possible.

## Aircraft RTK

The built-in RTK module of the aircraft can withstand strong magnetic interference from metal structures and high-voltage lines, ensuring safe and stable flight. When used with a D-RTK product (sold separately) or a DJI-approved Network RTK service, more accurate positioning data can be obtained.



- Visit <https://ag.dji.com/t25p/downloads> to view the accessory user guide and learn about how to use the product.
- 

## Enabling/Disabling RTK

Ensure that the RTK function is enabled and the RTK signal source is correctly set before each use. Otherwise, RTK cannot be used for positioning. Go to **Operation View** >  > **RTK** to view and check the settings.

Disable RTK Positioning if RTK is not in use. Otherwise, the aircraft is not able to take off when there is no differential data.

## Custom Network RTK

When using the network RTK service of a third party provider, follow the instructions below to set it up.

1. Make sure the remote controller is connected to the internet.
2. Go to **Operation View** > **RTK**, select **Custom Network RTK** as the RTK signal source. Tap **Edit** and input the required parameters.
3. Wait to connect to the server. The RTK status icon at the top of the Operation View will turn green, indicating that the aircraft has obtained and used the RTK data from the server.

## 1.3 Control Station

### Remote Controller

#### Overview

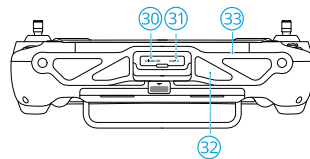
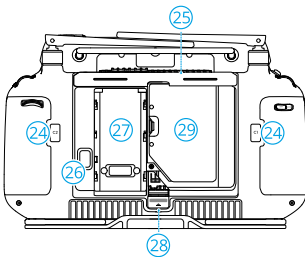
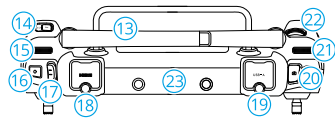
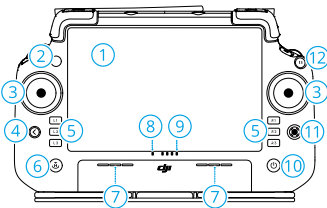

1. Touchscreen
2. Connection Status LED
3. Control Sticks
4. Back Button
5. L1/L2/L3/R1/R2/R3 Buttons

When buttons are displayed in the app near these physical buttons or the prompts in the app include L1/L2/L3/R1/R2/R3, press the

- corresponding button on the remote controller to operate instead of tapping the touchscreen.
6. Return to Home (RTH) Button
  7. Microphone
  8. Status LED
  9. Battery Level LEDs
  10. Power Button

- 11. 5D Button
- 12. Flight Pause Button
- 13. External Antennas
- 14. Customizable C3 Button
- 15. Left Dial
- 16. Spray/Spread Button
- 17. Flight Mode Switch
- 18. HDMI™ Port
- 19. USB-A Port  
For connecting devices such as the RTK Dongle, intelligent charger or multifunctional inverter generator.
- 20. FPV/Map Switch Button
- 21. Right Dial
- 22. Scroll Wheel
- 23. Internal Antennas
- 24. C1/C2 Buttons
- 25. Rear Cover
- 26. Battery Release Button
- 27. Battery Compartment  
For installing the WB37 Intelligent Battery.
- 28. Rear Cover Release Button
- 29. Dongle Compartment
- 30. microSD Card Slot
- 31. USB-C Port
- 32. Air Intake
- 33. Bracket

## Charging the Batteries

---

- ⚠ • Use the DJI 65W Portable charger to charge the remote controller. Otherwise, use a locally certified USB-C charger with a maximum rated power and voltage of 65 W and 20 V.
  - Recharge the battery at least every three months to prevent over discharging. The battery depletes when stored for an extended period.
- 

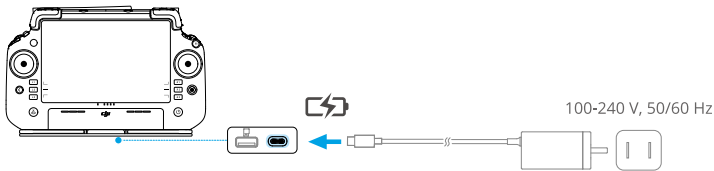

## Checking the Battery Level

Press the power button on the remote controller once to check the internal battery level.

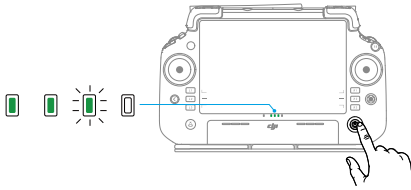

## Using the Remote Controller

### Controlling the Spraying System

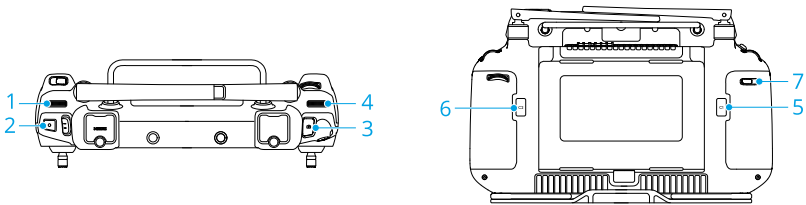

#### 1. Left Dial

In Manual operation mode, turn left to reduce and right to increase the spray rate.\*  
The app indicates the current spray rate.

\* Spray rate may vary according to the sprinkler model and viscosity of the liquid.

#### 2. Spray/Spread Button

In Manual operation mode, press to start or stop spraying.

#### 3. FPV/Map Switch Button

In Operation View in DJI Agras, press to switch between FPV and Map View.

#### 4. Right Dial

When the aircraft is not performing a Mapping operation, turn the dial to adjust the tilt of the FPV camera.



#### 5. Button C1

Press to record Point A of the route in a Route (A-B) operation or steer the aircraft left in a Manual Plus operation.



#### 6. Button C2

Press to record Point B of the route in a Route (A-B) operation or steer the aircraft right in a Manual Plus operation.

## 7. Button C3

In the DJI Agras app, tap  >  in Operation View to customize the function of this button.

## Customizable Button

The L1, L2, L3, C3 and 5D buttons are customizable. Open DJI Agras and enter Operation View. Tap  >  to configure the functions of these buttons.

## Button Combinations

Some frequently-used features can be activated by using button combinations. Use the back button and the other button at the same time to execute a specific function.

Button Combinations	Description
Back Button + Left Dial	Adjust the screen brightness
Back Button + Right Dial	Adjust the system volume
Back Button + Spray Button	Record the screen
Back Button + FPV/Map Switch Button	Screenshot the screen
Back Button + 5D Button	Toggle up - Home Toggle down - Quick Settings Toggle left - Recently opened apps

## Operating the Touchscreen

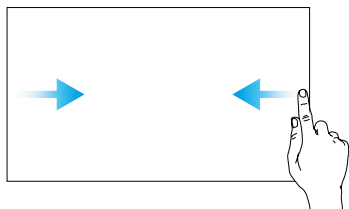

Slide from the left or right to the center of the screen to return to the previous screen.

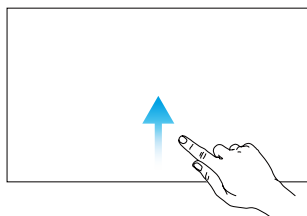

Slide up from the bottom of the screen to return to the homepage.

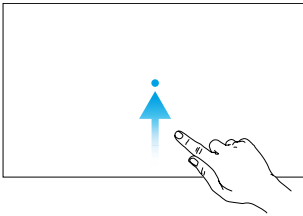

Slide up from the bottom of the screen and hold to access recently opened apps.

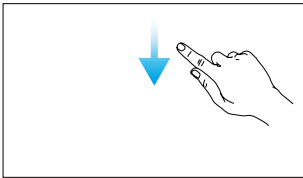

Slide down from the top of the screen to open the status bare when in DJI Agras. The status bar displays information such as time, Wi-Fi signal, and remote controller battery level.

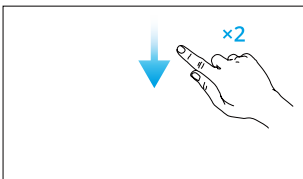

Slide down twice from the top of the screen to open Quick Settings when in DJI Agras. Slide down once from the top of the screen to open Quick Settings when not in DJI Agras.









## Remote Controller LEDs

### Status LED

Blinking Pattern	Descriptions
— Solid red	Disconnected from the aircraft.
..... Blinking red	The battery level of the aircraft is low.
..... Solid green	Connected with the aircraft.
..... Blinking blue	The remote controller is linking to an aircraft.
— Solid yellow	Firmware update failed.
— Solid blue	Firmware update successful.
..... Blinking yellow	The battery level of the remote controller is low.
..... Blinking cyan	Control sticks not centered.

### Battery Level LEDs

The battery level LEDs indicate the battery level of the remote controller.

Blinking Pattern	Battery Level
	88-100%
	75-87%
	63-74%
	50-62%
	38-49%
	25-37%
	13-24%
	0-12%

## Remote Controller Alert

The remote controller vibrates or beeps to issue an error alert or warning. For detailed information, see the real-time prompts on the touchscreen or in the DJI Agras app. To disable some alerts, slide down from the top and select **Do Not Disturb** in Quick Settings.

Any voice prompts and alerts will be disabled in Silent mode, including alerts during RTH and low battery alerts for the remote controller or aircraft. Fly with caution.

## Optimal Transmission Zone

Lift and adjust the antennas. The strength of the remote controller signal is affected by the position of the antennas. Adjust the direction of the external RC antennas of the remote controller so that the controller and aircraft are within the optimal transmission zone.

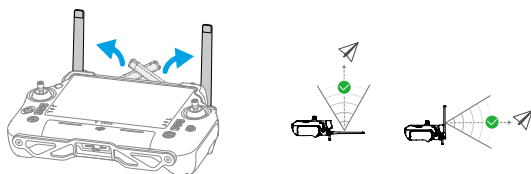

## Linking the Remote Controller

The remote controller is linked to the aircraft by default. Linking is only required when using a new remote controller for the first time. After linking, make sure that the transmission distance can reach 300 m before using.

1. Power on the remote controller and open DJI Agras. Power on the aircraft.

2. Go to **Operation View** > ⚙ > ↗, and tap **Linking**. The status LED blinks blue and the remote controller beeps twice repeatedly, indicating that the remote controller is ready for linking.
3. Press and hold the power button on the intelligent flight battery for five seconds. The battery LEDs blink in sequence, indicating that the linking is in progress.
4. The Status LED on the remote controller glows solid green if linking is successful. If linking fails, enter linking status again and retry.

## HDMI Settings

The touchscreen can be shared to a display after connecting the HDMI port of the remote controller.

The resolution can be set by entering ⚙ > **Display** > **HDMI**.

## Installing the Strap

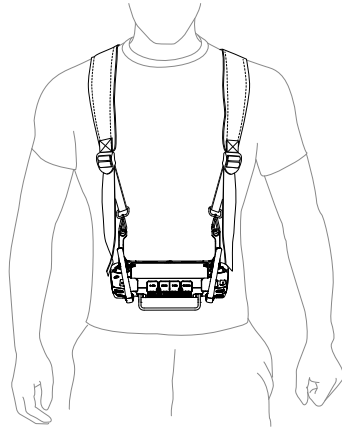
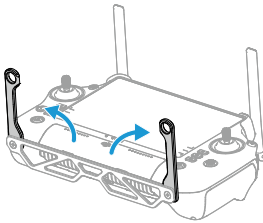

After use, hold the remote controller with one hand and unlatch the strap hooks from the brackets. Put the remote controller down, and then take off the strap.

## DJI Agras App

Users can check the real-time status of the aircraft, operation status, and connected devices via DJI Agras.

💡 The following image is for reference only. The actual interface varies according to the app version.

---

## Home Screen

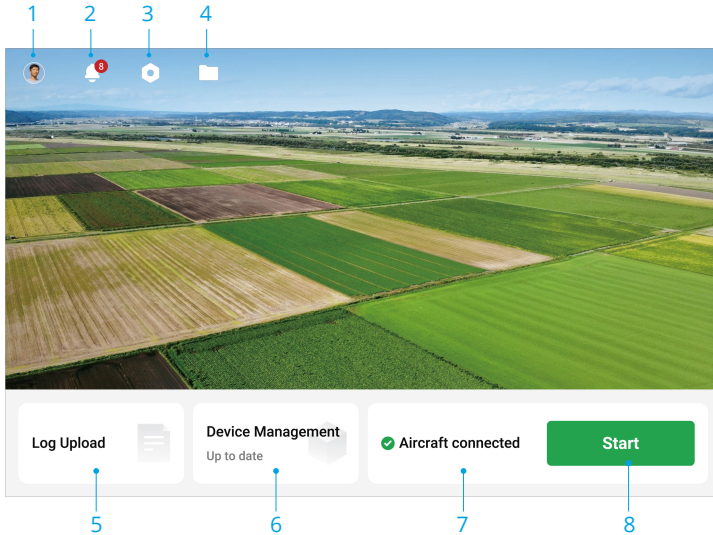

**1. User Info**

**2. Notification Center**

Check notifications about any changes to the aircraft, users, or operations.

**3. General Settings**

**4. Document Management**

Tap to view local and cloud files.

**5. Log Upload**

View solutions for errors of each module and upload error logs.

**6. Device Management**

Tap to check the device connection status and firmware version, or enter the Health Management System (HMS).

**7. Aircraft Connection Status**



**8. Start**

Tap to enter Operation View.

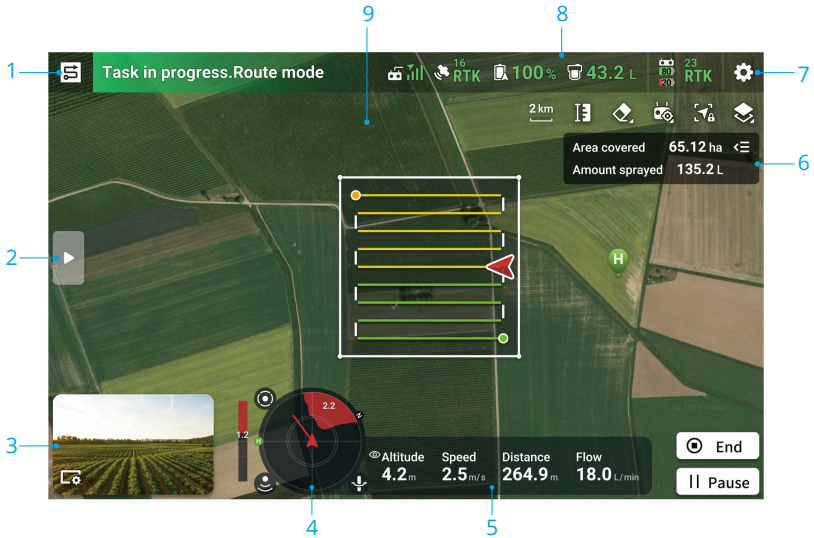
## Operation View



1. Mode Switch Button
2. Tap to expand detailed list.
3. FPV Camera View
4. Radar Indicator

Displays information such as the orientation of the aircraft and the Home Point. When Obstacle Avoidance is enabled, it will display information about the detected obstacles. Tap the radar indicator to enable or disable Obstacle Avoidance , Altitude Stabilization , and Obstacle Bypassing  functions.

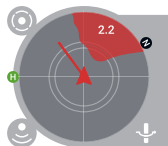

5. Flight Telemetry
6. Operation Status
7. Settings

Tap to set the parameters of all settings.

8. Status Bar

Displays information about the aircraft and remote controller.

## 9. Obstacle Indicator

If obstacle avoidance is enabled, a red zone will appear at the top of the screen when an overhead obstacle is detected.

# 1.4 Command and Control Link (C2 Link)

The command and control (C2) link between the aircraft and control station is established using technology with the OcuSync video transmission antennas and system, offering stable and reliable communication. The C2 link provides the control signal from the control station to the aircraft, facilitating real-time operations.

Refer to the Performance and Limitations section to learn the detailed specifications.

## 2 Performance and Limitations

### 2.1 Performance

#### T25P

Basic Empty Weight	33 kg
Max Payload	20 kg (for spraying) 25 kg (for spreading)
Max Takeoff Weight	60 kg (for spreading)
Hovering Time <sup>[1]</sup>	7 min (takeoff weight of 53 kg with a 15500mAh battery) 14 min (takeoff weight of 33 kg with a 15500mAh battery)
Max Flight Time <sup>[1]</sup>	8.6 min (takeoff weight of 53 kg with a 15500mAh battery)
Top Speed/Never Exceed Speed	10 m/s
Max Ascent/Descent Speed	2 m/s
Max Configurable Flight Radius	2000 m
Max Configurable Flight Altitude	100 m
Max Wind Resistance	6 m/s
Max Takeoff Altitude	4500 m
IP Rating <sup>[2]</sup>	IP67
Flight Battery	Type: Li-ion Capacity: 15500 mAh
Operating Frequency <sup>[3]</sup> & Transmitter Power (EIRP)	2.4000-2.4835 GHz: <33 dBm (FCC), <20 dBm (SRRC/CE/ MIC) 5.725-5.850 GHz: <33 dBm (FCC), <30 dBm (SRRC), <14 dBm (CE)

[1] Tested at sea level with wind speed lower than 3 m/s and a temperature of 25° C (77° F). For reference only. The data may vary depending on the environment. Actual results shall be as tested.

[2] Under stable laboratory conditions, the core modules of the aircraft has a protection rating of IP67 (IEC 60529). However, this protection rating is not permanent and may reduce over time after long-term use due to aging and wear. The product warranty does not cover water damage. The protection ratings of the aircraft mentioned above may decrease in the following scenarios:

- There is a collision and the seal structure is deformed.
- The seal structure of the shell is cracked or damaged.
- The waterproof covers are not properly secured.

[3] 5.8 and 5.1GHz frequencies are prohibited in some countries. In some countries, the 5.1GHz frequency is only allowed for use indoors.

## 2.2 Prohibited Maneuvers

The following actions are prohibited.

- Be under the influence of alcohol, drugs, or anesthesia, or suffering from dizziness, fatigue, nausea, or any other conditions, whether physical or mental, that could impair your ability to operate the aircraft safely.
- Stop the motors mid-flight. NOTE: this is not prohibited in an emergency situation where doing so will reduce the risk of damage or injury.
- Upon landing, power off the remote controller before powering off the aircraft.
- Drop, launch, fire, or otherwise project any dangerous payloads on or at any buildings, persons, or animals, or which could cause personal injury or property damage.
- Fly the aircraft recklessly without any plan.
- Use this product for any illegal or inappropriate purpose such as spying, military operations, or unauthorized investigations.
- Use this product to defame, abuse, harass, stalk, threaten, or otherwise violate the legal rights of others, such as the right of privacy and publicity.
- Trespass onto private property of others.

## 2.3 Flight Environment Requirements

- During takeoff, landing, and flight, keep away from roads, water surfaces, and obstacles such as utility poles, high-voltage lines, and trees. Maintain a safe distance of more than 10 m from crowds and animals.
- Only fly in moderate weather conditions with temperatures between 0° to 40° C (32° to 104° F). DO NOT use the aircraft in severe weather conditions including wind speeds exceeding 6 m/s, heavy rain (precipitation rate exceeding 25 mm (0.98 in) in 12 hours), snow, ice, fog, and lightning.
- To prevent health hazards to nearby people and to ensure effective spray, operate the aircraft to spray in wind speeds below 6 m/s. It is recommended to operate the aircraft in wind speeds below 3 m/s when using herbicide, fungicides, or insecticides that are easy to drift and that pose phytotoxic risks.
- DO NOT fly over 4.5 km (14,763 ft) above sea level.

- DO NOT fly the aircraft in areas that severely affect GNSS signal, such as indoors or under bridges. Only operate the aircraft with a strong GNSS signal.
- Fly in open areas.
- Avoid flying in areas with high levels of electromagnetism, including mobile phone base stations and radio transmission towers.
- The payload capacity will decrease with increasing altitude. Be careful when flying 2 km (6,560 ft) or more above sea level as battery and aircraft performance may be reduced.
- In low temperature environments, make sure that the flight battery is fully charged and be sure to reduce the payload of the aircraft. Otherwise, it will affect flight safety or a takeoff limit will occur.
- DO NOT use the aircraft near accidents, fire, explosions, floods, tsunamis, avalanches, landslides, earthquakes, dust, or sandstorms.

## 3 Normal Procedures

### 3.1 Airspace Environment

#### GEO (Geospatial Environment Online) System

The DJI Geospatial Environment Online (GEO) System is a global information system that provides real-time information on flight safety and restriction updates and prevents UAVs from flying in restricted airspace. Under exceptional circumstances, restricted areas can be unlocked to allow flights. Prior to that, you must submit an unlocking request based on the current restriction level in the intended flight area. The GEO system may not fully align with local laws and regulations. You are responsible for your own flight safety and must consult with the local authorities on the relevant legal and regulatory requirements before requesting to unlock a restricted area. For more information about the GEO system, visit <https://fly-safe.dji.com>.

#### GEO Zones

The DJI GEO system designates safe flight locations, provides risk levels and safety notices for individual flights, and offers information on restricted airspace. All restricted flight areas are referred to as GEO Zones, which are further divided into Restricted Zones, Authorization Zones, Warning Zones, Enhanced Warning Zones, and Altitude Zones. You can view such information in real-time in DJI Agras. GEO Zones are specific flight areas, including but not limited to airports, large event venues, locations where public emergencies have occurred (such as forest fires), nuclear power plants, prisons, government properties, and military facilities. By default, the GEO system limits takeoffs and flights in zones that may cause safety or security concerns. A GEO Zone map that contains comprehensive information on GEO Zones around the globe is available on the official DJI website: <https://fly-safe.dji.com/nfz/nfz-query>.

#### Flight Restrictions

The following section describes in detail the flight restrictions for the above mentioned GEO Zones.

##### Restricted Zones (Red)

UAVs are prohibited from flying in Restricted Zones. If you have obtained permission to fly in a Restricted Zone, visit <https://fly-safe.dji.com> or contact [flysafe@dji.com](mailto:flysafe@dji.com) to unlock the zone.

##### Scenario

**Takeoff:** the aircraft motors cannot be started in Restricted Zones.

**In Flight:** when the aircraft flies inside a Restricted Zone, a 100-second countdown will commence in DJI Agras. When the countdown is finished, the aircraft will land immediately in semi-automatic descent mode and turn off its motors after landing.

**In Flight:** when the aircraft approaches the boundary of a Restricted Zone, the aircraft will automatically decelerate and hover.

### **Authorization Zones (Blue)**

The aircraft will not be able to take off in an Authorization Zone unless it obtains a permission to fly in the area.

#### **Scenario**

**Takeoff:** the aircraft motors cannot be started in Authorization Zones. To fly in an Authorization Zone, the user is required to submit an unlocking request registered with a DJI-verified phone number.

**In Flight:** when the aircraft flies inside an Authorization Zone, a 100-second countdown will commence in DJI Agras. When the countdown is finished, the aircraft will land immediately in semi-automatic descent mode and turn off its motors after landing.

### **Warning Zones (Yellow)**

A warning will be displayed when the aircraft flies inside a Warning Zone.

#### **Scenario**

The aircraft can fly in the zone but the user is required to understand the warning.

### **Enhanced Warning Zones (Orange)**

When the aircraft flies in an Enhanced Warning Zone, a warning will be displayed prompting the user to confirm the flight path.

#### **Scenario**

The aircraft can continue to fly once the warning is confirmed.

### **Altitude Zones (Gray)**

The aircraft altitude is limited when flying inside an Altitude Zone.

#### **Scenario**

When the GNSS signal is strong, the aircraft cannot fly above the altitude limit.

**In Flight:** when the GNSS signal changes from weak to strong, a 100-second countdown will commence in DJI Agras if the aircraft exceeds the altitude limit. When the countdown is finished, the aircraft will descend below the altitude limit and hover.

When the aircraft approaches the boundary of an Altitude Zone and the GNSS signal is strong, the aircraft will decelerate automatically and hover if the aircraft is above the altitude limit.

- 💡 • **Semi-Automatic Descent:** all stick commands except the throttle stick command and the RTH button are available during descent and landing. The aircraft motors will turn off automatically after landing. It is recommended to fly the aircraft to a safe location before the semi-automatic descent.

## Flight Altitude and Distance Limits

Max altitude restricts the flight altitude of the aircraft, while max distance restricts the flight radius around the Home Point of the aircraft. These limits can be set in DJI Agras.

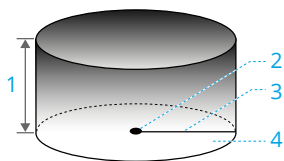

1. Max Altitude
2. Home Point (Horizontal Position)
3. Max Distance
4. The altitude of the aircraft during takeoff (when altitude stabilization is unavailable).

The distance of the aircraft to the surface (when altitude stabilization is functioning normally).

### Strong GNSS Signal

#### Flight Restrictions

Max Altitude	Altitude of the aircraft cannot exceed the value set in DJI Agras.
Max Distance	The straight-line distance from the aircraft to the Home Point cannot exceed the max flight distance set in DJI Agras.

### Weak GNSS Signal

#### Flight Restrictions

Max Altitude	Altitude of the aircraft cannot exceed the value set in DJI Agras.
Max Distance	No limits

- ⚠️ • If the aircraft flies into a Restricted Zone, it can still be controlled, but the aircraft can only fly in a backward direction.
- DO NOT fly near airports, highways, railway stations, subway stations, city centers, or other busy areas. Make sure the aircraft is visible at all times.

- If there is no GNSS signal during the flight, the aircraft will automatically enter Attitude mode, and the app will display a safety warning. At this time, the aircraft's position information will no longer be updated. Fly with caution to avoid exceeding the max flight distance restricted by regulations.



## 3.2 Interference with Flight Controller and Communications

- Fly in open areas. Tall buildings, steel structures, mountains, rocks, or forests may affect the accuracy of the on-board compass and block both GNSS and remote control signals.
- Avoid using wireless devices that use the same frequency bands as the remote controller.
- When using with multiple aircraft, make sure that the distance between each aircraft is more than 10 m to avoid interference.
- The sensitivity of the radar module may be reduced when operating several aircraft within a short distance. Operate with caution.
- Be alert when flying near areas with magnetic or radio interference. These include but are not limited to, high-voltage power lines, large-scale power transmission stations or mobile base stations, broadcasting towers, and electronic interference devices. Failing to do so may compromise the transmission quality of this product or cause transmission errors which may affect flight orientation and location accuracy. The aircraft may automatically enter failsafe RTH if severe interference causes signal loss.
- When using the RTK function, operate in an open environment free from radio interference. DO NOT obstruct the RTK antennas when used.
- If the RTK Dongle is used for field planning, the module should be disconnected from the remote controller after planning is completed. Otherwise, it will affect the communication performance of the remote controller.

## 3.3 Calibrating the Compass

-  • It is important to calibrate the compass. The calibration result affects the flight safety. The aircraft may malfunction if the compass is not calibrated.
- DO NOT calibrate your compass where there is a chance of strong magnetic interference. This includes areas where there are utility poles or walls with steel reinforcements.

- DO NOT carry ferromagnetic materials with you during calibration such as keys or mobile phones.
  - After calibrating successfully, the compass may be abnormal when you place the aircraft on the ground. This may be because of underground magnetic interference underground. Move the aircraft to another location and try again.
- 

Calibrate the compass when prompted by the app. Tap  >  , select **Sensor Calibration** and then **Compass Calibration**. Then follow the on-screen instructions. It is recommended to calibrate the compass with an empty tank.

## 3.4 Basic Flight

### Pre-Flight Checklist

- Make sure all devices are fully charged.
- Only use genuine components. Unauthorized parts may cause system malfunctions and compromise flight safety.
- Make sure all components are in good condition and not blocked by foreign object, including but not limited to motors, propellers, vision system, radar module, and antennas. Replace aged or broken parts in time.
- Make sure all parts are mounted securely and cables are connected correctly and firmly, including but not limited to the aircraft battery, spray tank, and arm locks.
- Make sure the aircraft and its components are all in good working order, damage-free, and functioning well. Components include, but are not limited to, the remote controller, compass, propulsion system, radar module, and payload system.
- Make sure the spraying system is not blocked and has no leaks, and that the sprinklers work properly.
- Compass is calibrated after being prompted to do so in the app.
- Always wear a helmet during the operation and maintain a safe distance of more than 6 m from the aircraft. Make sure there are no other personnel, vehicles, or obstacles around the aircraft.
- Make sure to clear any debris in the task area that may affect flight, such as plastic bags, empty fertilizer bags, and plastic films that can be easily blown away.
- Make sure the app is functioning properly. Without the flight data recorded by the DJI Agras app and stored in your remote controller, in certain situations such as the loss of your aircraft, we may not be able to provide aftersales support or assume liability.

- Examine and check all warning messages on the aircraft status list displayed in the app prior to each flight to ensure there are no errors.
- The DJI Agras app will intelligently recommend the payload weight limit for the tank according to the current status and surroundings of the aircraft. **DO NOT** exceed the recommended payload weight limit when adding material to the tank. Otherwise, the flight safety may be affected.

## Starting and Stopping the Motors

### Starting the Motors

Perform one of the Combination Stick Commands (CSC) as shown below to start the motors. Once the motors have started spinning, release both sticks simultaneously.

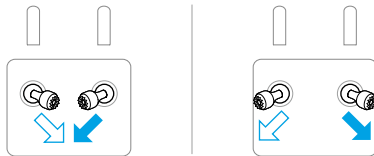

### Stopping the Motors

When the aircraft has landed, push and hold the throttle stick down until the motors stop.

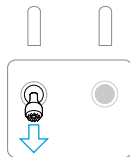

- 
- ⚠ • Spinning propellers can be dangerous. Stay away from spinning propellers and motors. **DO NOT** start the motors in confined spaces or when there are people nearby.
  - Keep your hands on the remote controller when the motors are spinning.
- 

### Stopping the Motors Mid-Flight

Press and hold the C1, C2, and flight pause button simultaneously until the motor stops if there is an emergency.

-  DO NOT stop the motors mid-flight. Otherwise it will cause the aircraft to crash. The motors should only be stopped mid-flight if an emergency situation occurs, such as if the aircraft is involved in a collision.
- 

## Take Off

1. Place the aircraft on open, flat ground with the rear of the aircraft facing you.
2. Pour liquid into the spray tank, and tighten the cover.
3. Power on the remote controller, make sure that the DJI Agras app is functioning normally. Then power on the aircraft. Make sure the remote controller is linked to the aircraft.
4. If using RTK for positioning, make sure that the RTK signal source is correctly set. Go to **Operation View** >  > **RTK**, and set the RTK signal source.  
Disable RTK Positioning if RTK is not in use. Otherwise, the aircraft is not able to take off when there is no differential data.
5. Wait for satellites to be searched, make sure that there is a strong GNSS signal and RTK is ready. Perform the Combination Stick Command (CSC) to start the motors. (If the RTK is not ready after waiting for an extended period, move the aircraft to an open area with a strong GNSS signal.)
6. Select the desired operation or flight mode. Push the throttle stick up to take off.

- 
-  • Before the operation, make sure that the remote controller stick control and aircraft response are normal. If there are any abnormalities, land immediately and solve the issue.
- If the app indicates a weak connection signal, improve the signal strength as prompted before taking off.
- 

## Landing

1. Exit the operation to manually control the aircraft for landing. To land, pull down the throttle stick to descend until the aircraft touches the ground.
2. After landing, pull down the throttle stick and hold it in that position until the motors stop.
3. After the motors stop, power off the aircraft before turning off the remote controller.

- 
-  • When the low battery warning prompt appears in the app, fly the aircraft to a safe area and land as soon as possible. Stop the motors and replace the battery.
-

The aircraft will automatically descend and land when the critical low battery warning prompt appears in the app. Landing cannot be cancelled.

- Operate the aircraft with caution when controlling the aircraft manually during auto landing.

### 3.5 Cruise/Maneuvering Flight

#### Controlling the Aircraft

The control sticks of the remote controller can be used to control the aircraft movements. The control sticks can be operated in Mode 1, Mode 2, or Mode 3, as shown below.

The default control mode of the remote controller is Mode 2. In this manual, Mode 2 is used as an example to illustrate how to use the control sticks. The more the stick is pushed away from the center, the faster the aircraft moves.

Mode 1

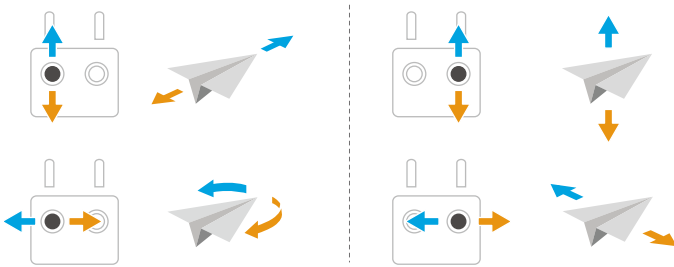

Mode 2

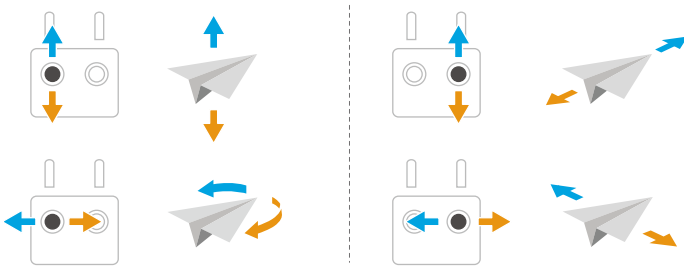

### Mode 3

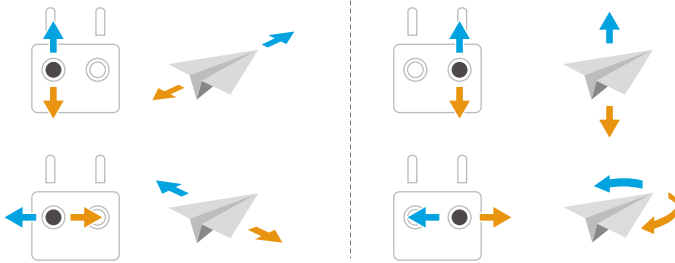

## Operation Mode

### Mapping Operation Modes

Mapping operation modes can capture images of farmland and orchards. The app will reconstruct an HD map using the photos after the flight so that users can plan a field on the HD map.

### Spraying Operation Modes

Spraying operation modes include Route, Manual, and Fruit Tree operation modes. Select the desired mode for spray according to the operation scenarios.



Refer to the [Operation](#) section for more information.



- Make sure that you fully understand the aircraft's behavior under each operation mode before use.
  - Make sure to maintain a visual line of sight (VLOS) with your aircraft and fly with caution during the operation.
  - Operate in Route or Fruit Tree operation mode when receiving a strong GNSS signal.
- 

## Return to Home

The Return to Home (RTH) function will automatically fly the aircraft back to the last recorded Home Point. RTH can be triggered in three ways: the user actively triggers RTH, the aircraft has low battery, or the remote control signal has been lost (Failsafe RTH is triggered). If the aircraft records the Home Point successfully and the positioning system is functioning normally, when the RTH function is triggered, the aircraft will automatically fly back and land at the Home Point.

-  Home Point: The Home Point will be recorded at takeoff as long as the aircraft has a strong GNSS signal. If it is necessary to update the Home Point during a flight (such as if you have changed your position), the Home Point can be manually updated in  >  in DJI Agras.

## Notices

-  • RTH will not work if there is a weak or no GNSS signal.
- Make sure the space above the remote controller's GNSS module is not obstructed and that there are no tall buildings around when updating the home point.
- Tall buildings may adversely affect RTH. Therefore, it is important to set an appropriate failsafe altitude before each flight. Adjust the aircraft location, altitude, and speed while returning home to avoid obstacles when there is a strong remote controller signal.
- RTH function may be affected by the weather, the environment, or any nearby magnetic fields.
- The aircraft will not enter RTH if RTH is triggered when the aircraft is within a 3m radius of the Home Point, but the remote controller will still sound an alert. Exit RTH to cancel the alert.

## Smart RTH

Press and hold the RTH button on the remote controller to enable Smart RTH, and the aircraft will return to the latest updated Home Point. Both Smart and Failsafe RTH use the same procedure. With Smart RTH, you may control the altitude of the aircraft to avoid collisions when returning to the home point. Press the RTH button once or push the pitch stick to exit Smart RTH and regain control of the aircraft.

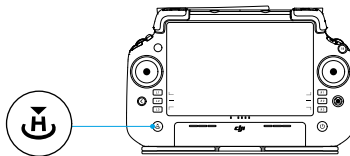

## Low Battery RTH

If the Low Battery Action is set to RTH in the Aircraft Battery settings in the app, the aircraft will pause the operation and enter RTH automatically when the aircraft battery

level reaches the low battery threshold. During RTH, users can control the altitude of the aircraft to avoid collisions when returning to the home point. Press the RTH button once or push the pitch stick to exit RTH and regain control of the aircraft.

The aircraft will not enter RTH if the Low Battery Action is set to Warning in the Aircraft Battery settings in the app.

## Failsafe RTH

The aircraft will activate the signal lost action if the remote controller signal is lost. The action can be set to RTH, Hover, or Land in the app. When the remote controller signal is lost, the aircraft will enter Failsafe RTH and fly to the most recently recorded Home Point if the action is set to RTH. The RTH continues if the remote controller signal is recovered, and users can control the aircraft using the remote controller. Press the RTH button once to cancel RTH and regain control of the aircraft.

### RTH Procedure

After the aircraft enters Failsafe RTH:

- When the aircraft's altitude is higher than the preset RTH altitude, it will fly to the Home Point at the current altitude.
- When the aircraft's altitude is lower than the preset RTH altitude, it will ascend to the RTH altitude before flying to the Home Point.

The aircraft will land and the motors will stop after reaching the Home Point.

## Obstacle Avoidance During RTH

In an optimal operating environment, obstacle avoidance during RTH is available. If there is an obstacle on the return path during RTH, the aircraft will bypass to avoid it or decelerate to hover (the obstacle avoidance action depends on the selected operation terrain). The aircraft exits RTH and waits for further commands after hovering.

- 
- 💡 • If RTH is triggered during Route or Fruit Tree operations, the aircraft will calculate an RTH path that circumvents obstacles added while planning the task area.
  - If connection points were added before performing the operation, the aircraft will fly to the Home Point via the connection points. Connection points cannot be deleted during the operation. Adjust the connection points after tapping the End button.
  - Exit automatic RTH and control the aircraft to return to home manually if it is not necessary to fly through the connection points to return.
-

## Landing Protection Function

Landing Protection activates during auto landing. The procedure is as follows:

1. After arriving at the home point, the aircraft descends to a position 3 m above the ground and hovers.
2. Control the pitch and roll sticks to adjust the aircraft position and make sure the ground is suitable for landing.
3. Pull down the throttle stick or follow the onscreen instructions in the app to land the aircraft.

---

 When using fixed RTK positioning, the aircraft will land directly instead of entering Landing Protection. Landing Protection is still available if the aircraft is performing a Fruit Tree operation planned using DJI Terra.

---

## 3.6 Flight Data

Flight data is automatically recorded to the internal storage of the aircraft. You can connect the aircraft to a computer via the USB port and export this data via DJI Assistant 2 or DJI Agras app.

## 3.7 Storage, Transportation and Maintenance

### Storage and Transportation

- 
-  • Before transportation, ensure to remove the battery from the aircraft and fold and secure the propellers.
- Remove or empty the spray tank for transportation or long-term storage.
  - Keep the aircraft clean and dry, and ensure there is no liquid remaining in the tank, flow meter, pumps, or hoses. Store the aircraft in a cool dry place. Recommended storage temperature is between -20° and 40° C (-4° and 104° F).
  - Charge the remote controller immediately if the power level reaches 0%. Otherwise, the remote controller may be damaged due to being over discharged for an extended period. Discharge the remote controller to between 40% and 60% if stored for an extended period.
-

## Maintenance

Maintain the product every 100 flights or after flying for over 20 hours in order to keep the product in the best condition possible and reduce potential safety hazards.

- Check for and replace worn propellers.
- Check for loose propellers. Replace propellers and propeller washers if needed.
- Check for aging plastic or rubber parts.
- Check for poor atomization of the sprinklers. Clean the centrifugal disks of the sprinklers thoroughly. Replace the centrifugal disks in the case of severely poor atomization.
- Replace the spray tank strainer.



Refer to the product manuals for information on how to clean, inspect, and maintain the product.

---

## 4 Emergency Procedures

### 4.1 Obstacle Avoidance

During flight, the aircraft will automatically brake to avoid detected obstacles within the declared obstacle avoidance performance boundaries. If the aircraft does not automatically brake, use the remote controller to manually control the aircraft to brake or avoid the obstacles.

When there are moving aerial obstacles (such as third-party drones or manned aircraft), check the prompts in the app, observe the surroundings, and manually control the aircraft to descend or ascend to avoid the obstacles.

### 4.2 Critical Low Battery/Critical Overheated Warning

The aircraft will automatically descend and land when the critical low battery warning or critical voltage warning prompt appears in the app. Landing cannot be cancelled. If the critical overheated warning prompt appears in the app, control the aircraft to land or return to home immediately.

### 4.3 Loss of Navigation Systems

When using fixed RTK positioning, the aircraft will switch to GNSS if RTK is unavailable during flight. If GNSS signal is also unavailable, the aircraft will switch to Attitude (ATTI) mode automatically, and a prompt will appear in the app to remind users to fly with caution and land as soon as possible. In A-mode, the aircraft may drift and only supports manual flight.

### 4.4 Loss of C2 Link

If the remote controller signal is lost for more than 3 seconds, the aircraft will automatically perform the signal lost action, which can be set to RTH (default), landing, or hover. If set to RTH, the aircraft will enter failsafe RTH. During the RTH process, if the connection is restored, the pilot can cancel RTH and regain control of the aircraft.

## 4.5 Single Propulsion Failure

1. Use the remote controller to adjust the flight direction, allowing the aircraft to fly forward along the arm with the failed motor.
2. Manually control the aircraft to return to home or land following the above flight direction.
3. After the aircraft lands, take photos of the site, and upload the complete flight logs.
4. Contact official support or an authorized dealer.

If more than one propulsion motor fails, the aircraft will crash. Refer to the Aircraft Crash section for more information.

## 4.6 Aircraft Out of Control

Follow these emergency procedures if the aircraft loses control (for example, when the aircraft may crash into a crowd or building).

1. Evacuate people within a 50-meter radius of the aircraft.
2. Control the aircraft to hover using the remote controller.
3. If the aircraft is unable to hover, press the the RTH button to trigger Smart RTH.
4. If RTH cannot be triggered, press and hold the C1, C2, and flight pause buttons on the remote controller until the motors stop. The aircraft will immediately stop to reduce the risk of damage or injury. Stopping motors mid-flight will cause the aircraft to crash.

In case of a crash, refer to the Aircraft Crash section for more information.

## 4.7 Aircraft Crash

Follow these emergency procedures if the aircraft crashes.

1. Evacuate people within a 50-meter radius of the aircraft.
2. After the aircraft lands, take photos of the site, and upload the complete flight logs.
3. DO NOT use the battery again. Remove the battery from the aircraft and place it in an open area away from flammable materials.
4. Contact official support or an authorized dealer. In case of fire, refer to the Fire section for more information.

## 4.8 Flyaway

1. Users can search for the aircraft according to the location of the aircraft and remote controller displayed on the map in the app.
2. If the GNSS signal of the aircraft is lost after the aircraft flies away, then the aircraft will not be displayed on the map in the app. Users can estimate the location of the aircraft according to its last location, flight speed, and heading before the loss of the GNSS signal.
3. Record details of lost aircraft incidents, including aircraft model, time, location, task status, direction in which the aircraft was lost, and other relevant information.
4. Contact official support or an authorized dealer.

## 4.9 Fire

1. Move the flammable materials surrounding the battery to a safe distance of more than 5 m away.
2. If the fire is controllable, use a large amount of sand to cover the location of the fire and pour water to cool the battery until there is no smoke coming out. Use fire-resistant gloves or other protective tools to avoid direct contact with the battery. Move the battery to a container with an appropriate amount of salt solution, and then fully immerse the battery in the solution. Leave the container in a cool place for more than 72 hours to fully discharge the battery and take out the battery and dispose of it.
3. If the fire is uncontrollable, double check that there are no flammable materials surrounding the battery, extend the safety distance to more than 10 m, and evacuate people from the surrounding area. Wait until the battery burns out and the fire is extinguished in order to avoid any further accidents.

## 5 Operation



It is recommended to click the link below or scan the QR code to watch the tutorial video.



<https://ag.dji.com/t25p/video>

### 5.1 Calibrating the Flow Meter

When to Recalibrate:

- Using a liquid of a different viscosity.
- After completing the operation, there is a large error between the actual amount and the theoretical amount.

#### Calibrating

1. Fill the spray tank with approximately 2 L of water.
2. Go to **Operation View** > ⚙ > 📏, tap **Calibration of Flow Calibration** and calibration will start automatically. The result will be displayed in the app when completed.

After calibrating successfully, users can proceed with the operation.

If the calibration fails, tap the notification to view and resolve the problem. Recalibrate once the problem is resolved.







- Calibration can be canceled during the process, and the flow rate accuracy will be based on the data before this calibration.
  - After replacing or mounting the additional sprinklers, it is necessary to calibrate the flow rate of the delivery pump according to the instructions.
- 

### 5.2 Mapping Operation

#### Operation Procedure

1. In Operation View, tap the mode switch button on the upper left side, and select **Route Mapping** or **Fruit Tree Mapping**.

2. When using Crosshair to add points, add boundary points on the map to create a field, then adjust the flight route.
3. Tap  to save the field. The added field will be displayed in the field list.
4. Select the task, tap  and move the slider to take off. The aircraft will fly along the route to perform the mapping task. Wait for the reconstruction to complete. The reconstructed map will be displayed on the original map.

- 
-  • If the mapping operation is paused or stopped during flight and a new mapping field is added, users can only view the paused or stopped operation in the operation list and the operation cannot be resumed.
  - If the user exits a mapping operation during reconstruction, select the operation in the operation list and tap  to restart reconstruction.
- 

## Reconstruction Result Application

1. After reconstruction is completed, **Route Planning** and **Identify Field** can be performed on the HD map. The results can be saved to the field list and applied in Route or Fruit Tree operation mode.
2. Upload the mapping results to the cloud to bind them to a personal account. Users can log in the account on another remote controller and download the HD map from the cloud. Tap  in Operation View, and set Overlay HD Map to **Personal Account Map**.

## 5.3 Spraying Operation

### Downloading Prescription Maps

Download prescription maps first in order to perform variable rate fertilization. <sup>[1]</sup>

- Go to Home Screen in DJI Agras, tap  > **Cloud** and select the files in **Prescription Map** tab to download.
- Users can also store prescription tasks planned in DJI Terra or downloaded from DJI SmartFarm Web on a microSD card, and then insert the microSD card into the remote controller to import the tasks to DJI Agras.

[1] Use DJI SmartFarm Web with the required firmware version to download prescription maps in the app. Please update the firmware to the required version.

## Downloading/Importing Operations

- Download from Cloud: Go to Home Screen in DJI Agras, tap **☰** > **Cloud** and select the files in **Task** tab to download.
- Import from the microSD card: Insert the microSD card with the planning data from DJI Terra into the microSD card slot on the remote controller. Go to Home Screen in DJI Agras, tap **☰** > **microSD** and select the data and tap **Import**.

The downloaded or imported operations will be displayed in the operation list.

## Planning an Operation

### Planning Route Operation





1. Go to Operation View in the app, tap the mode switch button on the upper left side, select **Route** and then the task type, then tap **Add**.
2. When using Crosshair to add points, add boundary points on the map to create a field, then add points to mark **Obstacles** and **Non-Spraying Area**.
  - When selecting **Multiple Fields**, you can add multiple boundary points at once. Then, tap the corresponding boundary points according to the field division to connect them and create individual fields.
  - When selecting **A-B Route**, the aircraft can start the operation directly after recording point A and B. Refer to the [Performing A-B Route Operation](#) section for details.
  - When selecting **Custom**, you can add waypoints to generate a flight route.
3. The app will generate the route after creating the field. Adjust the route parameters in the **Flight Route Settings** panel.
4. Tap  to save the field. The added field will be displayed in the field list.

### Planning Fruit Tree Operation

1. Go to Operation View in the app, tap the mode switch button on the upper left side, select **Fruit Tree**, and then plan the field on the reconstructed HD map or edit the task in the field list.
2. When using Crosshair to add points, add boundary points or calibration points on the map. When planning on the reconstructed map, tap **3D** to check the relative height of the route to the ground and the surrounding objects in 3D view.
3. The app will generate the route after creating the field. Adjust the route parameters in the **Flight Route Settings** panel.



4. Tap  to save the field. The added field will be displayed in the field list.

## Notices

-  If **Add Point with RC** or **Add Point with Aircraft** is selected, walk with the remote controller to the desired position or fly the aircraft to the desired position and tap **Add**.
- When adding points using a mobile phone, install the RTK dongle on the phone and tap **Field > Plan Field** in DJI SmartFarm, then add points on the map.
- A more accurate map is required to add points using the crosshairs. It is recommended to use the HD map reconstructed in a mapping operation, or tap  and input a suitable map source link in the Overlay HD Map to improve the accuracy of the added points.
- In the route operation, a field can be divided into multiple task areas through **Divide Field** and task parameters can be set separately.
- To edit a field, select it in the field list and tap  to enter Edit mode.
- Tap  and select **Multitask**, then you can select multiple fields and perform **Merge Field**.

## Performing an Operation

### Performing Route/Fruit Tree Operation

1. Place the aircraft on open, flat ground with the rear of the aircraft facing you. Power on the remote controller and then power on the aircraft.
2. Go to Operation View and select the operation mode, then select a field and tap .
3. Set parameters in the Task Settings.
4. Adjust the route:
  - If the location of the planned field is different from the actual field, tap **Rectify Offset** and adjust the field position using the fine tuning buttons.
  - Drag the map and tap **Connection Point** to add a connection point at the crosshair position, avoiding obstacles on the connection or RTH route.
5. Add prescription maps if necessary: Tap  and select a prescription map from the list for a preview. Tap **OK** to apply the selected prescription map to the field.
6. Tap , check the aircraft status and task settings, and move the slider to take off. The aircraft will perform the operation automatically, and the route is generated based on the added obstacles and connection points.



- After setting the parameters in Route operation mode, tap **New Template** and the current parameter configurations can be saved as a template for repeat operations.
- In Fruit Tree operation mode, users can set the parameters under the **Amount** or **Flow** panel according to their needs.
- The aircraft will fly to the first waypoint at the preset connection routing altitude and return to the flight route with this altitude after the operation is paused and resumed. If the task is applied after takeoff, the aircraft will fly to the first waypoint at the current altitude.



- Only take off in open areas and set an appropriate Connection Routing and RTH Altitude according to the operating environment.
- The operation is automatically cancelled if the motors are started before beginning the operation. You will need to recall the operation in the task list.
- Once started, the aircraft flies to the starting point of the route and locks its heading in the direction of the first turning point for the duration of the flight route.
- The aircraft does not spray while flying along route spacing and non-spraying area, but automatically sprays while flying along the rest of the route. Users can adjust the parameters in the app.
- During an operation, users cannot control the heading of the aircraft, but can move the roll stick or pitch stick to pause the operation. The aircraft will hover and record the breakpoint, and then the aircraft can be controlled manually. Tap **Resume** and the aircraft will return to the selected return point automatically and resume the operation. Pay attention to aircraft safety when returning to a breakpoint.

## Performing A-B Route Operation

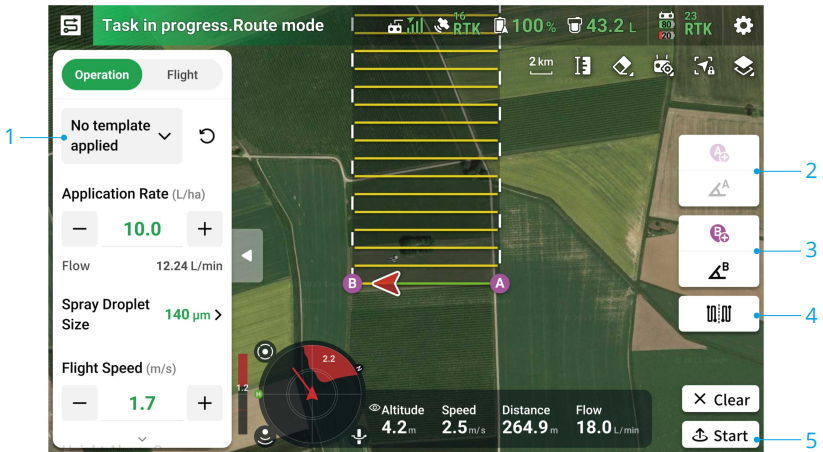

1. Set Operation Parameters.
2. Fly the aircraft to the starting point and hover, then tap A (B) onscreen or press the preset customizable button on the remote controller to record Point A and B.
3. If the heading for Point A or B needs to be adjusted, tap the button for Point A (B) heading onscreen after the point is recorded, and move the yaw stick on the remote controller. The heading of the aircraft corresponds to the heading for Point A or B, which is indicated by a dotted line on the map. Tap the button again to set the current heading for Point A or B.
4. After Point A and B are recorded, the app produces Route R or Route R' by default. Tap this button to switch to Route L or Route L'.

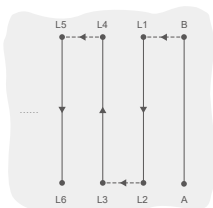

Route L

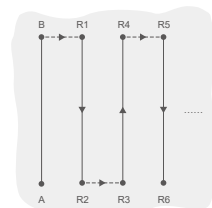

Route R

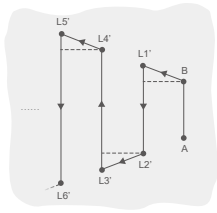

Route L'

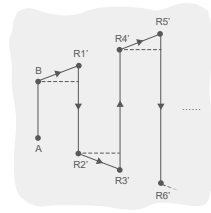

Route R'

5. Tap , check the aircraft status and task settings, and then move the slider to take off. The aircraft will perform the operation automatically.





- If the number of operated flight routes exceeds 3 (including from Point A to Point B), users can save them as a field after tapping **End**.



- Make sure to first record Point A and adjust its heading before recording Point B and adjusting its heading.
- Users cannot adjust the position of Point A or B after they have been recorded. Start a new A-B Route operation if adjustment of Point A or B is required.
- Make sure to maintain a visual line of sight (VLOS) with your aircraft during the operation.
- Make sure that there is a strong GNSS signal during operation. Otherwise, the operation may not be completed successfully.
- During the operation, the aircraft will spray liquid only when flying along the route parallel to the line from A to B, and will stop spraying on other route segments.

## Multitask

Select multiple fields for continuous operations after enabling **Multitask**.

1. Tap  and select multiple fields from the list, or select the fields on the map. The selected fields will be numbered in the order of selection. Then tap **Use**.
2. Set task parameters for each field individually. Select the number on the settings panel or tap the corresponding field on the map to switch between fields. Tap **Apply to All Selected** to apply the currently displayed parameters to all selected fields.
3. Tap  and the aircraft will perform the operations in sequence. Users can adjust task parameters for ongoing and pending operations.
4. After each operation is completed, the app will display Task Summary. The aircraft will automatically fly to the next field and continue the operation.

## Manual Operation

This mode is ideal for small or irregularly-shaped operating areas.

1. In Operation View, tap the mode switch button on the upper left side and select **Manual**.
2. Choose **Manual** or **Manual Plus**, then set the **Operation** and **Flight** parameters.
3. Control the aircraft to fly to the task area and perform the spraying task using the remote controller buttons. In Manual Plus mode, tap **←** or **→** onscreen, and the aircraft will fly to the left or right at the preset distance for route spacing. The aircraft automatically sprays when accelerating forward, backward or diagonally, but does not spray when flying sideward.

- 
- ⚠ • Under optimal working conditions, and if the altitude stabilization function is enabled, the radar module maintains the distance between the aircraft and vegetation when spraying.
  - The heading of the aircraft will be locked after **Course Lock** is enabled. Users can control all other movements but not the flight direction of the aircraft.
  - Users can adjust the spray amount, flight speed and height above the vegetation during Manual Plus operation while the line spacing cannot be adjusted.
- 

## 5.4 Operation Resumption

When exiting a Route or Fruit Tree operation, the aircraft will record a breakpoint. The Operation Resumption function allows the user to pause an operation temporarily to refill the spray tank, change the battery, or avoid obstacles manually. Afterwards, resume operation from the breakpoint.

### Recording a Breakpoint

When exiting a task, the aircraft will record a breakpoint if GNSS signals are strong and the breakpoint recording conditions are met. If GNSS signals are weak, the aircraft will enter Attitude mode and exit the current operation. The last position where GNSS signals were strong will be recorded as a breakpoint.



## Resumption Procedure

1. When exiting a task with strong GNSS signals and meeting the breakpoint recording conditions, the aircraft will record the current location as the breakpoint.
  2. Fly the aircraft to a safe location after performing the necessary operations on the aircraft (such as replacing the battery, refilling, or controlling the aircraft to avoid obstacles).
  3. Select the breakpoint or return point on the screen.
  4. Tap **Resume** and the aircraft will return to the selected return point automatically and resume the operation.
- 
- If connection points are added before the operation, the aircraft will fly back to the breakpoint through the connection points after tapping **Resume**.
  - If an operation has been exited by tapping **End**, the connection points will no longer be available. Add connection points before performing the operation again if necessary.
- 
5. If an obstacle is detected while flying back to the breakpoint or return point, the aircraft will bypass to avoid it or decelerate to hover. After hovering, users need to manually control the aircraft. Refer to [Resuming Operation](#) for details.

## Smart Resume

For Route and Fruit Tree operations, Smart Resume becomes available if any of the following conditions is met. The app will calculate the optimal return point according to the breakpoint and the aircraft location to reduce the flying distance when carrying a heavy payload.

- After tapping **Pause** and landing the aircraft on the ground.
- When exiting an operation by tapping **End** and then restarting it through the **In Progress** tab.

Before starting the task, enable **Smart Resume** in  > . Users can also enable/disable this feature in the menu on the left side of the screen after the aircraft has landed.



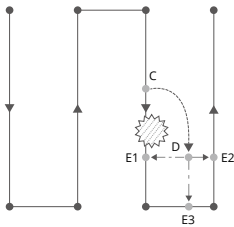

## Resuming Operation

During Route or Fruit Tree operations, users can manually control the aircraft if it fails to auto-bypass obstacles or encounters an emergency such as abnormal aircraft behavior. The following instructions describe how to avoid obstacles manually:

## Manual Obstacle Avoidance



### Legend

-  Obstacle
-  Turning Point
-  Operation Route
-  Manual Fly Route
-  Auto Return Route

### 1. Exiting an Operation

During the task, if the aircraft fails to auto-bypass an obstacle, users need to manually control the aircraft to avoid the obstacle. The aircraft will automatically switch to Manual operation mode and pause the task, record the current position as a breakpoint (Point C), and hover after completing the corresponding flight behavior.

### 2. Bypassing Obstacles

After switching to Manual operation mode, users can control the aircraft to avoid the obstacle from Point C to D.

### 3. Resuming Operation

Select one of the return points marked as E1, E2, or E3. Tap **Resume** and the aircraft flies from the point marked D to the selected return point following a perpendicular line.



- Repeat the instructions above to exit and resume operation in the event of an emergency when returning to the route, such as whenever obstacle avoidance is required.





- The amount of selectable return points is related to the position of the aircraft. For example, there is no E3 (points on non-spraying route) for Route operation mode. Select according to the app display.
- Make sure that the aircraft has completely avoided the obstacle before resuming operation.
- In the event of an emergency, make sure that the aircraft is operating normally and fly the aircraft manually to a safe area to resume operation.

## 5.5 Empty Tank Warning

The aircraft can calculate the empty tank point and display it on the map. When the spray tank is empty, the app will display a notification.

- The empty tank point will not be displayed on the map if the tank is not calculated to run out before the end of the task route.
  - For Route and Fruit Tree operations, when adding liquid to the spray tank or adjusting the operation parameters, the empty tank point will update dynamically on the operating route according to the amount of added liquid and the adjusted settings.
  - Users can set the action the aircraft will perform for empty tank point.
- 

## Usage

1. Enable **Display Empty Tank Point** in  >  and set the empty tank action.
2. When an empty tank warning appears in the app, the sprinklers automatically turn off.
3. Land the aircraft and stop the motors. Refill the spray tank and tightly secure the cover.
4. Select an operation mode and continue the operation.

## 6 Intelligent Flight Battery

### 6.1 Overview

The DB1580 Intelligent Flight Battery is used as an example.

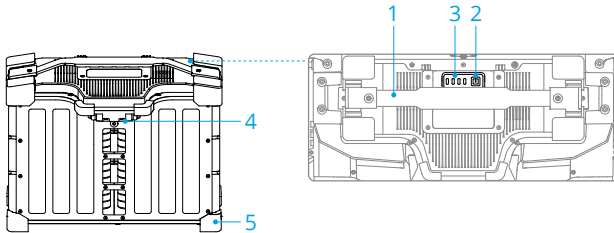

1. Handle
2. Power Button
3. Status LEDs
4. Power Port
5. Rubber Caps

### 6.2 Warnings

Refer to the Safety Guidelines and the stickers on the battery before use. Users shall take full responsibility for all operation and usage.

- ⚠ • DO NOT use or charge the battery near heat sources, such as inside a vehicle on hot days, near a furnace or heater, or near the exhaust outlet of the generator.
- Make sure the battery is powered off before connecting to or disconnecting from the aircraft. DO NOT connect or disconnect the battery while it is powered on. Otherwise, the power ports may be damaged.
- DO NOT use the battery in strong electrostatic or electromagnetic environments or near high-voltage transmission lines. Otherwise, the battery circuit board may malfunction, which could cause a serious flight hazard.
- Put out a battery fire using sand, a fire blanket, or a dry powder or carbon dioxide fire extinguisher according to the actual situation.
- DO NOT connect the positive and negative poles of a battery with a cable or other metal objects. Otherwise, the battery will short-circuit.

- Always use a clean, dry cloth when cleaning the battery terminals. Otherwise, this may affect the battery connection, resulting in energy loss or failure to charge.
- DO NOT fly when the battery power level is below 15% to avoid damage to the battery and flight risks.
- Make sure the battery is correctly connected. Otherwise, the battery may overheat or even explode due to abnormal charging. Only use approved batteries from authorized dealers. DJI assumes no responsibility for any damage caused by using batteries that are not approved.
- Make sure that the battery is placed on a flat surface to avoid damage to the battery from sharp objects.
- DO NOT place anything on a battery or charging device. Otherwise, the battery may be damaged, which may lead to fire hazards.
- The battery is heavy. Be careful when moving the battery to avoid dropping it. If the battery is dropped and damaged, immediately leave the battery in an open area away from people and combustible objects. Wait 30 minutes and then soak the battery in salt water for 24 hours. After making sure the power has completely run out, dispose of the battery in accordance with local laws.
- DJI does not take any responsibility for damage caused by third-party chargers.
- DO NOT charge the battery near flammable materials or on flammable surfaces such as carpet or wood. DO NOT leave the battery unattended during charging. There should be a distance of at least 30 cm between the battery station and any charging batteries. Otherwise, the battery station or charging batteries may be damaged by excessive heating and may even lead to a fire hazard.
- DO NOT immerse the battery in water to cool it down or when it is charging. Otherwise, the battery cells will corrode causing serious damage to the battery. Users accept full responsibility for damage to the battery caused by immersing the battery into water.
- Keep the battery dry at all times.
- Make sure the battery is powered off before charging. After charging is complete, power off the battery before disconnect it from the charging device. Otherwise, the battery ports may be damaged.





- Make sure the battery is fully charged before each flight.
  - Before operating in a low-temperature environment, make sure the battery is at least above 5° C (41° F). Ideally, above 20° C (68° F). Warm up the battery by hovering the aircraft.
-









## 6.3 LED Patterns

### Checking the Battery Level

Press the power button once to check the current battery level.





The battery level LEDs display the power level of the battery during charging and discharging. The statuses of the LEDs are defined below:

-  LED is on
-  LED is flashing
-  LED is off

Blinking Pattern	Battery Level
	88-100%
	76-87%
	63-75%
	51-62%
	38-50%
	26-37%
	13-25%
	0-12%

### Battery Level LEDs











The table below shows the battery level during charging.

Blinking Pattern	Battery Level
	0-50%
	51-75%
	76-99%
	100%

-  • When the battery cell temperature is below 15° C (59° F), the blinking frequency of the LEDs slows down and the charging speed is relatively slow.
- The battery level indicated by the LEDs is affected by environmental factors such as temperature and elevation.

## Battery Error LED Patterns

The table below shows battery protection mechanisms and corresponding LED patterns.

LEDs	Blinking Pattern	Description
	LED 2 and 4 blink three times per second	Aircraft short circuit/overcurrent at power on
	LED 2 and 4 blink twice per second	Undervoltage at power on
	LED 2 blinks twice per second	Overcurrent detected
	LED 2 blinks three times per second	Battery System Error
	LED 3 blinks twice per second	Overcharge detected
	LED 3 blinks three times per second	Charging device over-voltage
	LED 4 blinks twice per second	Temperature is too low when charged/power on
	LED 4 blinks three times per second	Temperature is too high when charged/power on
	All 4 LEDs blink fast	The battery is abnormal and unavailable
	Display the current battery level, light up for 2 seconds every 1 second.	Battery installed incorrectly. Unable to provide high current to start the generator and aircraft normally.

If overcurrent at power on is detected or a short circuit occurs, unplug the battery, then check if there are foreign objects in the port.

If undervoltage at power on is detected, charge the battery before use.

If the battery temperature is abnormal, wait for the temperature to return to normal. The battery will then automatically power on or resume charging.

For other situations, after resolving the issue (overcurrent, excess battery voltage due to overcharging, or excess charging device voltage), press the power button to cancel the LED indicator protection alert and unplug and plug in the charger again to resume charging.

If the battery is not installed correctly, clean the connector of the battery, aircraft, and charging device, then reinstall the battery.

## 6.4 Storage and Transportation

- ⚠ • Power off and disconnect the battery from the aircraft or other devices during transportation or long-term storage.
- If the battery level is critically low, charge the battery to a power level of 40% to 60%. DO NOT store a battery with a low power level for an extended period. Otherwise, the performance will be negatively affected.
- The battery must be stored in a dry environment.
- DO NOT place the battery near explosive or hazardous material or near metal objects such as eyeglasses, watches, jewelry, and hairpins.
- DO NOT attempt to transport a damaged battery or a battery with a power level higher than 30%. Discharge the battery to 25% or lower before transportation.
- If storing the battery for more than three months, it is recommended to store the battery in a battery safety bag or battery safety box in an environment at a temperature range from -20° to 40° C (-4° to 104° F).
- If a battery with a low power level has been stored for an extended period, the battery will be in deep hibernation mode. Charge to wake the battery.

## 6.5 Maintenance

- ⚠ • DO NOT clean the battery with water.
- Regularly check the terminals and battery ports. DO NOT clean the battery using alcohol or any other flammable liquid. DO NOT use a damaged charging device.
- Battery performance will be negatively affected if the battery is not used for an extended period.
- Fully charge and discharge the battery at least once every three months to ensure the performance of the battery.
- If a battery has not been charged or discharged for five months or more, the battery will no longer be covered by the warranty.

## 6.6 Disposal

- ⚠ • It is recommended to open the battery cover and put it in a 5% salt solution for more than two weeks to completely discharge the battery. Then dispose of

the battery in specific recycling boxes. Contact official support or an authorized dealer if you have any problems.

- The battery contains hazardous chemicals, DO NOT dispose of the battery in a regular waste disposal container. Strictly follow your local regulations regarding the disposal and recycling of batteries.
  - If the battery cannot be discharged completely, DO NOT dispose of the battery in a battery recycling box directly. Contact a professional battery recycle company for assistance.
-

## 7 Appendix

### 7.1 Specifications

Visit the following website for specifications.

<https://ag.dji.com/t25p/specs>

### 7.2 Firmware Update

#### Using DJI Agram

1. Power on the aircraft and remote controller. Ensure the aircraft is linked to the remote controller, and the remote controller is connected to the internet.
2. Run DJI Agram. A prompt will appear on the home page if new firmware is available. Tap to enter the Firmware Update view.
3. Tap Update All Selected, and DJI Agram will download the firmware for all selected devices and update automatically.
4. Make sure all the devices are connected to the remote controller and wait for the update to complete. The aircraft front indicators will blink yellow during update.
5. The aircraft front indicators will glow solid green after an update is completed. Restart the remote controller and the aircraft manually. If the indicators glow solid red indicating that a firmware update has failed, try running the update again.



Connect the device to the USB-A port on the remote controller to update the firmware of the intelligent charger or multifunctional inverter generator.

---

#### Using DJI Assistant 2

1. Connect the aircraft or remote controller to a computer separately, as the DJI Assistant 2 does not support updating multiple DJI devices at the same time.



Connect the USB-C port under the bottom cover on the front of the aircraft to a computer with a USB-C cable, and then power on the aircraft.

---

2. Make sure the computer is connected to the internet and the DJI device is powered on.
3. Launch DJI Assistant 2 and log in with a DJI account.
4. Tap the **firmware update** on the left side of the main interface.

5. Select the firmware version and click to update. The firmware will be downloaded and updated automatically.
6. When the "Update successful" prompt appears, the update is completed, and the DJI device will restart automatically.

## Notices

---

- ⚠ • Make sure to check all connections and remove the propellers from the motors before performing the firmware update.
  - Make sure the aircraft and remote controller are fully charged before updating the firmware.
  - DO NOT remove accessories or turn off the devices during the update process.
  - Make sure to update the remote controller's firmware to the latest version after you update the aircraft's firmware.
  - Keep people and animals at a safe distance during any firmware update, system calibration, and parameter setting procedures.
  - For safety, always update to the latest firmware version.
  - The remote controller may become unlinked from the aircraft after updating. Re-link the remote controller and aircraft.
  - If the USB-C port is not in use, make sure to attach the waterproof cover. Otherwise, water may enter the port which can short circuit.
- 

## 7.3 Using Enhanced Transmission

Enhanced Transmission integrates OcuSync video transmission technology with 4G networks. If the OcuSync video transmission is obstructed, experiencing interference, or used over long distances, 4G connectivity allows you to maintain aircraft control.

The usage requirements are as shown below:

- The aircraft needs to be installed with a DJI Cellular Dongle kit (sold separately).
- The remote controller can be equipped with a DJI Cellular Dongle or can be connected to a Wi-Fi hotspot to use Enhanced Transmission.

- 
- ⚠ • Enhanced Transmission is only supported in some countries and regions.
  - The DJI Cellular Dongle and its services are only available in some countries and regions. Comply with local laws and regulations and DJI Cellular Dongle Terms of Service.
-

## Inserting the nano-SIM Card

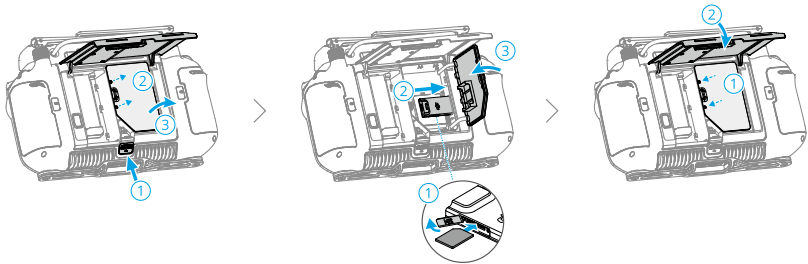

- ⚠ • It is strongly recommended to purchase a nano-SIM card which supports a 4G network from official channels of the local mobile network operator.
  - DO NOT use an IoT SIM card, otherwise the video transmission quality will be seriously compromised.
  - DO NOT use a SIM card provided by a virtual mobile network operator, otherwise it may lead to an inability to connect to the Internet.
  - If the SIM card is set with a password (PIN code), make sure to insert the SIM card into the smartphone and cancel the PIN code setting, otherwise it will fail to connect to the Internet.
- 
- 💡 • If the DJI Cellular Dongle kit requires to replace the nano-SIM card, remove the screws from the casing, then disconnect the DJI Cellular Dongle to replace. When reinstalling, make sure to correctly connect the DJI Cellular Dongle and tighten the screws.

## Installing the DJI Cellular Dongle

1. Install the DJI Cellular Dongle on to the aircraft.

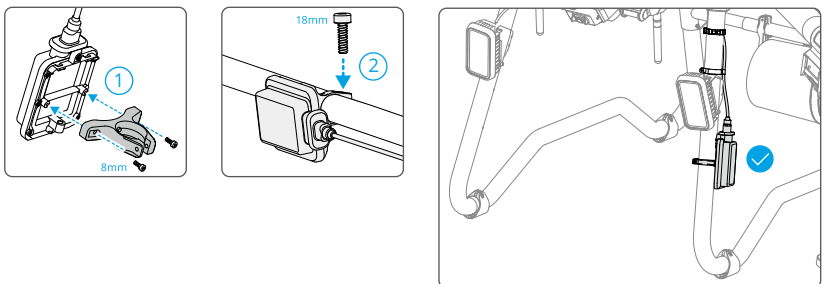

2. Install the DJI Cellular Dongle to the remote controller.

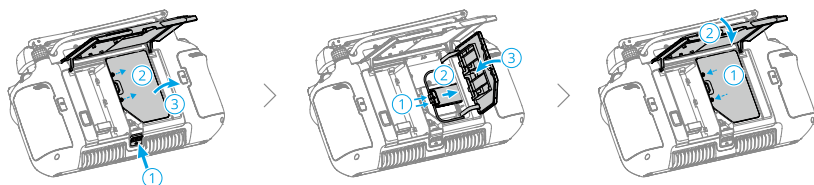

## Using Enhanced Transmission

Power on the remote control and the aircraft and make sure that they are connected normally. Ensure the remote controller is connected to the internet. Enhanced Transmission can be enabled in the app.

- Go to Operation View, then tap the video transmission signal icon to enable or disable **Enhanced Transmission** in the pop-up box.
- Go to Operation View, tap **⚙ > Video Transmission**, and enable or disable **Enhanced Transmission**.

When the 4G icon appears, it means that the enhanced transmission is available.

- 
- ⚠** • Pay close attention to the video transmission signal strength after enabling Enhanced Transmission. Fly with caution. Tap the video transmission signal icon to view the current OcuSync video transmission and 4G video transmission signal strength in the pop-up box.
- 

## Security Strategy

Based on safe flight considerations, Enhanced Transmission can only be enabled when the OcuSync video transmission is in effect. If the OcuSync link is disconnected during flight, it is not possible to disable Enhanced Transmission.

In a 4G-only transmission scenario, restarting the remote controller or DJI Agras will result in failsafe RTH. The 4G video transmission cannot be restored before the OcuSync link is reconnected.

In the 4G-only transmission scenario, a takeoff countdown will start after the aircraft lands. If the aircraft does not take off before the countdown ends, it will not be allowed to take off until the OcuSync link is restored.

## Remote Controller Usage Notes

If using the 4G network via the DJI Cellular Dongle, make sure to install the DJI Cellular Dongle correctly, and turn off the Wi-Fi of the remote controller while using Enhanced Transmission to reduce interference.

If using the 4G network by connecting the remote controller to a mobile device Wi-Fi hotspot, make sure to set the mobile device hotspot frequency band to 2.4 GHz and the network mode to 4G for a better video transmission experience. It is not recommended to answer incoming phone calls with the same smartphone or connecting multiple devices to the same hotspot.

## 4G Network Requirements

To ensure a clear and smooth video transmission experience when using Enhanced Transmission:

1. Make sure to use the remote controller and aircraft in locations where the 4G signal is close to full for a better transmission experience.
2. If the OcuSync signal is disconnected, the video transmission may lag and stutter when the aircraft relies fully on a 4G network. Fly with caution.
3. When the image transmission signal is weak or disconnected, return to home promptly. It is not recommended to continue the task relying on a 4G signal.
4. Fly the aircraft within the visual line of sight (VLOS) to ensure flight safety at night, as the 4G video transmission may have delays.
5. When the app prompts that the 4G video transmission signal is weak, fly with caution.

## 7.4 Recommended Maintenance Cycle

Module	Component	Recommended Inspection Time	Maximum Replacement Cycle	Item
<b>Remote Controller</b>				
Remote Controller	Remote controller	1 month	700 hours/36 months	<ol style="list-style-type: none"> <li>1. Clean and inspect for any signs of corrosion.</li> <li>2. Check if the device can be powered on normally and is functioning.</li> </ol>
<b>Aircraft</b>				

Aircraft Structure Part	Battery slider	Routine	700 hours/36 months	<p>Visually inspect the following items and replace if there are any abnormalities.</p> <ol style="list-style-type: none"> <li>1. Check if the rubber pad is missing or if the thickness is worn down to the plastic.</li> <li>2. Check if the plastic side guard is damaged or missing.</li> <li>3. Check if the roller is missing or stuck; if the roller rubber pad is detached.</li> <li>4. Check if the metal hook side is misshapen, and if the battery plugs into the latch normally.</li> <li>5. Check if the battery side clips are broken or missing, and if the function is normal.</li> </ol>
Aircraft Structure Part	Power board connector	1 month	700 hours/36 months	<ol style="list-style-type: none"> <li>1. Check if the battery is difficult to insert or remove from the aircraft.</li> <li>2. Check if the battery connector has verdigris corrosion or black dirt.</li> <li>3. Check if the power distribution board connector's current-carrying post has verdigris corrosion or black dirt.</li> </ol>
Aircraft Structure Part	Aircraft arm connector	1 month	700 hours/36 months	<ol style="list-style-type: none"> <li>1. Visually inspect the M1-4 aircraft arm connectors, locking screws, and the contact surface with the middle frame for cracks or misshapen parts.</li> <li>2. Check if the gap between the aircraft arm and the aircraft arm connector exceeds 2mm; if so, replace the corresponding material.</li> <li>3. Check if the middle frame locking screws are tightened.</li> </ol>

Aircraft Structure Part	Middle frame (including front frame and rear frame)	6 months	700 hours/36 months	<ol style="list-style-type: none"> <li>1. Check for cracks. Package broken.</li> <li>2. Check if the structure is loose.</li> <li>3. Inspect the frame for corrosion.</li> </ol>
Aircraft Structure Part	Middle frame fixing screw	1 month	700 hours/36 months	<ol style="list-style-type: none"> <li>1. Check if the screw is loose or broken.</li> <li>2. Check if the rubber seal is extruded or if there are any abnormal gaps.</li> </ol>
Aircraft Structure Part	Aircraft arm Lock lever	Routine	700 hours/36 months	Check if the lock lever is misshapen or cracked, if the secondary latch engagement is sufficient, and if the lever stiffness is adequate. If it is insufficient, adjust it to a moderate level refer to the recommended value table for specific stiffness.
Landing Gear Structural Part	Landing gear fixing screw	1 month	700 hours/36 months	Check if the screw is loose or broken.
Aircraft Arm Wiring	Aircraft arm power line	The new aircraft needs to undergo its initial inspection after the completion of 100 flights. Every 100 hours or one month	700 hours/36 months	Check if the power lines of the aircraft arm at the four connection points have worn through the protective tape, if there is any exposed wire insulation, or even damaged wire insulation.

Radar System	Front/rear radar	6 months	700 hours/36 months	<ol style="list-style-type: none"> <li>1. Check for any dents or other external damage.</li> <li>2. Clean and inspect the wire port for any signs of corrosion.</li> <li>3. Check if it powers on normally and functions correctly, with no errors in HMS.</li> </ol>
Radar System	Radar supporting piece	1 month	700 hours/36 months	<ol style="list-style-type: none"> <li>1. Inspect the radar crossbar.</li> <li>2. Inspect the radar mounting bracket.</li> <li>3. Inspect the front radar base.</li> </ol>
Battery Module	Battery connector	1 month	700 hours/36 months	<ol style="list-style-type: none"> <li>1. Clean and inspect for any signs of corrosion.</li> <li>2. Check if the device can be powered on normally and is functioning.</li> <li>3. Check if the reed has any collapse or blackening issues.</li> </ol>
Battery Module	Standard provided battery	Every 100 charging cycles or 1 month.	1000 cycles.	<ol style="list-style-type: none"> <li>1. Check for swollen, dents, or deformation.</li> <li>2. Clean the battery terminals.</li> <li>3. Charge and discharge at least once every three months to maintain battery activity.</li> </ol>
Cable Distribution Board Module	Payload control board	6 months	700 hours/36 months	<ol style="list-style-type: none"> <li>1. Clean and inspect for any signs of corrosion.</li> <li>2. Check if the device can be powered on normally and is functioning.</li> </ol>
Aerial-Electronics System	Aerial-Electronics System	6 months	700 hours/36 months	<ol style="list-style-type: none"> <li>1. Clean and inspect for any signs of corrosion.</li> <li>2. Check if the device can be powered on normally and is functioning.</li> </ol>

Power System	Motor	The new aircraft needs to undergo its initial inspection after the completion of 100 flights. Every 100 hours or one month. If there is a motor stalled error or motor/ESC temperature error, perform this check.	700 hours/36 months	<ol style="list-style-type: none"> <li>1. Tilt the motor to observe if there is any stuttering, or if the rotor is loose or detached.</li> <li>2. Check if the motor and motor base are loose (no movement is normal).</li> <li>3. Check if the motor cover is misshapen or damaged.</li> </ol>
Power System	Aircraft arm screw bolt	1 month	700 hours/36 months	There is one at the root of each aircraft arm (four in total). Inspect the aircraft arm for any gaps or looseness when folding it.
Power System	Propellers	The new aircraft needs to undergo its initial inspection after the completion of 100 flights. Every 100 hours or one month.	700 hours/36 months	<ol style="list-style-type: none"> <li>1. Check if the propeller is misshapen or damaged.</li> <li>2. Check if the propeller is loose.</li> <li>3. Check if the propeller is cracked.</li> </ol>

Power System	Propeller clamp	The new aircraft needs to undergo its initial inspection after the completion of 100 flights. Every 100 hours or one month.	700 hours/36 months	<ol style="list-style-type: none"> <li>1. Check if the propeller clamp is misshapen.</li> <li>2. Check if the propeller clamp movement is stuck.</li> </ol>
--------------	-----------------	---	---------------------	---

Power System	ESC	6 months	700 hours/36 months	<ol style="list-style-type: none"> <li>1. Clean and inspect for any signs of corrosion.</li> <li>2. Check if the device can be powered on normally and is functioning.</li> <li>3. Check if the ESC is loose</li> </ol>
--------------	-----	----------	---------------------	---

Positioning System	SDR antenna	6 months	700 hours/36 months	<ol style="list-style-type: none"> <li>1. Clean and inspect for any signs of corrosion.</li> <li>2. Check if the device can be powered on normally and is functioning.</li> </ol>
--------------------	-------------	----------	---------------------	---

Positioning System	RTK module	6 months	700 hours/36 months	<ol style="list-style-type: none"> <li>1. Clean and inspect for any signs of corrosion.</li> <li>2. Check if the device can be powered on normally and is functioning.</li> </ol>
--------------------	------------	----------	---------------------	---

Vision System	FPV/vision system	12 Months	700 hours/36 months	<ol style="list-style-type: none"> <li>1. Visually inspect if the vision system is misshapen or damaged.</li> <li>2. Visually inspect if the FPV is misshapen or damaged.</li> </ol>
---------------	-------------------	-----------	---------------------	--

**Spraying System**

Spraying System	Hose	Before daily operations	700 hours/36 months	Check if the aircraft arm pipelines are worn, pinched, or cracked.
-----------------	------	-------------------------	---------------------	--

Spraying System	Spray tank	6 months	700 hours/36 months	Daily cleaning
Spraying System	Hose connector	Before daily operations	700 hours/36 months	Check the spray tank hose connectors for any leaks at the sealing points. Poor hose sealing can cause air intake, affecting spray accuracy.
Spraying System	Delivery pump	After 100 hours, 1 month, or daily operation	Replace the pump head module after 500 hours. Replace the motor after 1000 hours.	<ol style="list-style-type: none"> <li>1. Disassemble the pump head, separate the pump shell, impeller module, and isolation sleeve, and check for any signs of a broken shaft, wear, or melting.</li> <li>2. Check the delivery pump motor port for any corrosion.</li> <li>3. Check for any powder adhesion on the impeller (after powder operation).</li> </ol>
Spraying System	Centrifugal sprinkler	100 hours or 1 month	700 hours/36 months	<ol style="list-style-type: none"> <li>1. Check for wear on the lower spinner disk and the lower cover of the centrifugal Motor.</li> <li>2. Check for corrosion at the centrifugal motor port.</li> <li>3. Inspect the pressure centrifugal funnel, perform a water test, and observe if the flow from the pressure nozzle is even.</li> <li>4. Check if the spray lance screws have any risk of loosening.</li> </ol>
Spraying System	Strainer Continuous liquid level meter	Before daily operations	700 hours/36 months	<ol style="list-style-type: none"> <li>1. Check whether the strainer is blocked.</li> <li>2. Check whether the hose of the liquid level meter is loose.</li> <li>3. Ensure the sensor of the liquid level meter is undamaged.</li> </ol>

Spraying System	Solenoid vent valve	Before daily operations	700 hours/36 months	<ol style="list-style-type: none"> <li>1. Check whether it can be opened normally.</li> <li>2. Check whether the solenoid valve is blocked (debris blockage).</li> </ol>
Spraying System	Flow meter	1 month	700 hours/36 months	<ol style="list-style-type: none"> <li>1. Clean and inspect for any signs of corrosion.</li> <li>2. Check if the device can be powered on normally and is functioning.</li> </ol>
<b>Generator</b>				
Generator	Generator	200 charges or 1 month	700 hours/36 months	<ol style="list-style-type: none"> <li>1. Check if the casing is cracked.</li> <li>2. Check if the battery terminals are dirty.</li> <li>3. Clean the fan.</li> </ol>

## 7.5 FAR Remote ID Compliance Information

The aircraft complies with the requirements of 14 CFR Part 89:

- The aircraft automatically initiates a pre-flight self-test (PFST) of the Remote ID system before takeoff and cannot take off if it does not pass the PFST <sup>[1]</sup>. The results of the PFST of the Remote ID system can be viewed in a DJI flight control app such as DJI Agras.
- The aircraft monitors the Remote ID system functionality from pre-flight to shut down. If the Remote ID system malfunctions or has a failure, an alarm will be displayed in a DJI flight control app such as DJI Agras.
- The user shall keep the DJI flight app running in the foreground and always allow it to obtain the location information of the remote controller.

[1] The pass criterion for PFST is that the hardware and software of the Remote ID required-data source and transmitter radio in the Remote ID system are functioning properly.



Contact

DJI SUPPORT



The terms HDMI, HDMI High-Definition Multimedia Interface, HDMI trade dress and the HDMI Logos are trademarks or registered trademarks of HDMI Licensing Administrator, Inc.

The content is subject to change without prior notice.

Download the latest version from



<https://ag.dji.com/t25p/downloads>

If you have any questions about this document, contact DJI by sending a message to [DocSupport@dji.com](mailto:DocSupport@dji.com).

DJI and AGRAS are trademarks of DJI.

Copyright © 2026 DJI All Rights Reserved.