



Matrice 200 Series

Maintenance Guide

V1.0 2017.12

To ensure flight safety and optimal performance, performing comprehensive and regular maintenance is recommended. This manual is intended to help users maintain their aircraft as well as possible and maximize reliability. Please note that the most effective way to extend the longevity of your aircraft is to inspect your aircraft before and after each flight to check for lodged objects and damaged parts and arrange repair if necessary.

We recommend conducting a pre and pro flight checklist each time you use the aircraft as outlined below.

I. Pre-Flight Checklist

1. Check the motors to confirm that they are rotating smoothly.
2. Check the propellers to confirm that they have not come loose.
3. Check the arm connectors to confirm that they are mounted firmly.
4. Ensure that the gimbal is rotating smoothly.
5. Ensure that the landing gears are mounted firmly and check the pins to confirm that they are inserted fully and tightly. (Fig. 1)
6. Ensure that the SD card cover and the rear cover are closed tightly.
7. When mounting an upward gimbal, ensure the gimbal cables are tied properly to avoid affecting the propellers.
8. An external GPS module is required when the upward gimbal is used. Ensure the GPS cable is connected to the rear port and the cable is tied properly. (Fig. 2)
9. When using the M210 RTK, check that the RTK antenna screws have been tightened. (Fig. 3)

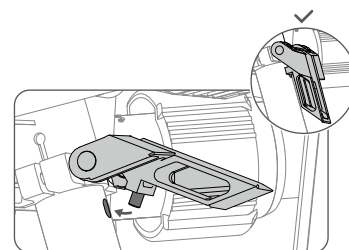

Fig.1

II. Post-Flight Checklist

Check below parts to avoid damage from water intrusion:

1. Intelligent Flight Batteries: Check that the connectors between the batteries and aircraft are dry. Dry the aircraft and batteries with a towel before storage.
2. FPV camera: Check that the camera is dry, especially along the roll axis where the camera meets the gimbal frame.
3. Aircraft arms: Ensure that the arms and arm locks are dry before unlocking and folding.
4. Rear aircraft port where pair button and USB port are housed: Keep dry and closed while flying. Ensure this area is dry before storage.
5. Downward gimbal connector: Keep dry, avoid disconnecting a camera and leaving the gimbal connector exposed in the rain or other wet-weather conditions.
6. Keep the gimbal and camera away from sand and water, and wipe them down if they've been exposed to sand or water.

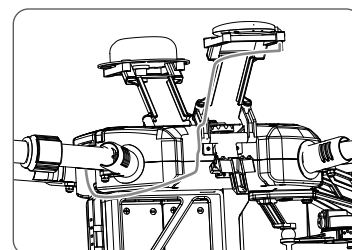

Fig.2

Check below parts to avoid damage from sand intrusion:

1. Aircraft arms: In cases where small objects like sand become lodged in the connector or arm, use a compressed air duster to remove these objects.
2. FPV camera: Check that the camera rotates smoothly along each axis. The camera will judder if objects are lodged inside.
3. Motors: Detach the propellers and start the motors. Listen carefully to see if there is any abnormal noise, please replace the motors.
4. Speaker port: keep it clean.

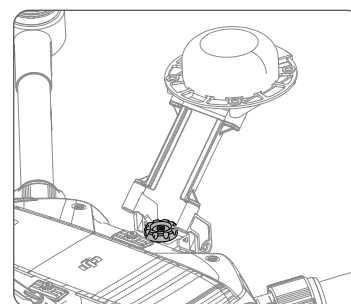

Fig.3

Checking for worn and loose parts:

1. Check that the gimbal protection cable is properly affixed to the gimbal frame. Replace it with a 0.5mm fishing line if it is damaged. (Fig. 4)
2. Check that the landing gear lock screw is tightened properly, and ensure that the landing gear firmly locks when connected to the drone. (Fig. 5)
3. Check that the battery release button is working normally, and the battery can be mounted firmly.
4. Check the propeller base screws are tightened. Ensure the spring elasticity is good and no foreign objects are stuck in the spring.
5. Ensure that the frame arm connectors are rotating smoothly.
6. Keep the upward infrared sensor lens clean and avoid wear and tear.
7. Check the following parts for signs of wearing: propellers, landing gears and motors. If these parts seem worn or damaged, please contact your reseller to schedule parts replacements.
8. Landing gears: Check the drawn line on the landing gear when mounted to ensure it has been installed. To determine whether the landing gear is properly mounted, firmly pull out the landing gear. If the attempt fails, this indicates it has been properly mounted.
9. Keep the vision system camera lenses clean and avoid scratching them.
10. Check the battery button is functioning normally. DO NOT press the button with sharp objects.
11. Check the battery light waterproof covers and make sure the covers have no signs of coming off.
12. Check the external GPS cable and connector to avoid damage.
13. Check the gimbal dampeners to avoid aging, cracking, or leaking. (Fig. 6)

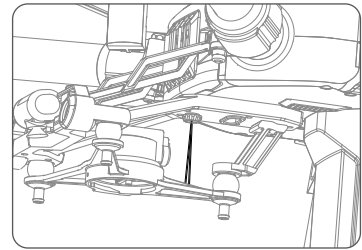

Fig.4

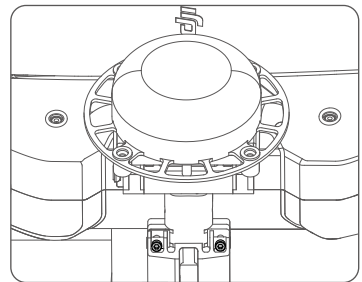

Fig.5

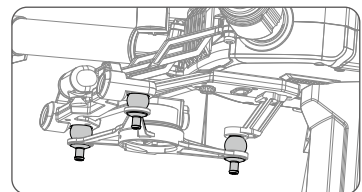

Fig.6

IV. Storage Tips

1. Avoid laying the drone on the battery compartment, as this will cause damage to the vision positioning system.
2. Be sure to store your batteries in a dry place.
3. Detach the upward single gimbal and the GPS module for storage.

V. Updating Apps and Firmware

Make sure you are using the latest firmware and apps when flying your M200 Series drone:

1. Check the latest firmware version in the release notes:
<https://www.dji.com/matrice-200-series/info#downloads>
2. DJI Pilot app download link:
<http://dl.djicdn.com/djipilot-official.apk>

Support Center Contact Info:

<http://www.dji.com/support>

The content is subject to change.

Download the latest version from
<https://www.dji.com/matrice-200-series>

MATRICE is a trademark of DJI.
Copyright © 2017 DJI All Rights Reserved.

Printed in China.